

IBM

# "Selectric" Typewriter

*Handwritten signature in blue ink*

## Adjustment Parts Manual

S241-5939-2

- IBM "Selectric" Typewriter (7XX)
- IBM "Selectric" II Typewriter (8XX)
- IBM "Selectric" III Typewriter (670X)
- IBM 96 "Selectric" Typewriter (9XX)

## INTRODUCTION

This manual is written for both U.S. and World Trade usage. It contains an adjustment section, a parts manual section, and a diagnostics section for the following products:

Product Name	Identification Code	Product Code
IBM "Selectric" Typewriter	7XX	21
IBM "Selectric" II Typewriter And IBM Correcting "Selectric" II Typewriter	8XX	26
IBM "Selectric" III Typewriter And IBM Correcting "Selectric" III Typewriter	670X	27
IBM 96-Character "Selectric" Typewriter	9XX	

**World Trade Note:** The IBM 96-Character "Selectric" Typewriter applies only to some World Trade countries.

## ADJUSTMENT SECTION

### Purpose

This section provides a reference for the most commonly used adjustments. Refer to other product service publications if additional information is needed.

### Adjustment Identification

The headline of each page shows the product name identification code, product code, and the name of the mechanism covered on that page. Each adjustment is indicated by a black frame number in the top left corner, followed by the adjustment

name and mechanism code/reference number. If one frame covers adjustments for more than one product or product level, they are indicated by the identification code and/or the level number. The machine mode, the view of the drawing, and safety precautions are also noted when required.

### Adjustment Sequence

The frame numbers indicate the sequence of adjustments. One adjustment could affect a following adjustment. Therefore, check all the following adjustments in that mechanism. A solid red bar indicates the end of the mechanism.

Red numbers on the bottom left corner of the frame indicate adjustments out of sequence that could be affected and should be checked.

### Adjustment Procedure

The part to be adjusted is colored red, and a red arrow shows the direction of movement. Tolerances and/or additional information on how to perform the adjustment are shown when required.

Always use the adjustment tolerance shown in the publication with the latest date.

### Call Reporting (U.S. Only)

Use the mechanism codes/reference numbers shown after the frame number and frame name for call reporting. The reference number is not always the number of the part that is colored red.

## PARTS MANUAL SECTION

### Introduction

This section contains parts drawings of mechanisms, reference numbers and other special information. It must be used with a separate part number/price list manual which contains reference numbers, part numbers, part descriptions and prices.

## Mechanism Identification

The headline of each page shows the product name, identification code and product code covered on that page. The headline of each frame (two frames per page) shows the mechanism name and the mechanism code covered in that frame. Some frames will show a model identification code after the mechanism name. Some mechanisms require more than one frame. However, each mechanism consists of a group of parts that work together to perform a function.

### Part Identification

Red numbers indicate the reference number of a part, a bill of material (B/M) or an assembly.

Red blocks within a frame indicate either one, or a combination of more than one, of the following:

- Differences between the models (7XX, 8XX, 670X, or 9XX)
- Different modes within the same model [for example: rotary backspace (RB/S) and non-rotary backspace (NRB/S)]
- Different machine sizes (7X1, 7X3, or 7X5 "Selectric" Typewriter)
- Different levels within the same model, mode, or size (level 1, level 2, etc.). (8X3 and 8X5 apply to the "Selectric" Typewriter.) (XX3 and XX5 apply to the "Selectric" Typewriter and "Selectric" II Typewriter.)
- Field replacement parts
- Bill of material (B/M) or assemblies (shown with a description — parts shown in the drawing)
- World Trade applications or differences

If different levels exist, which can be used for all models, modes or sizes, only the newest level is shown in the drawing. However, the part number/price list manual will show all level parts.

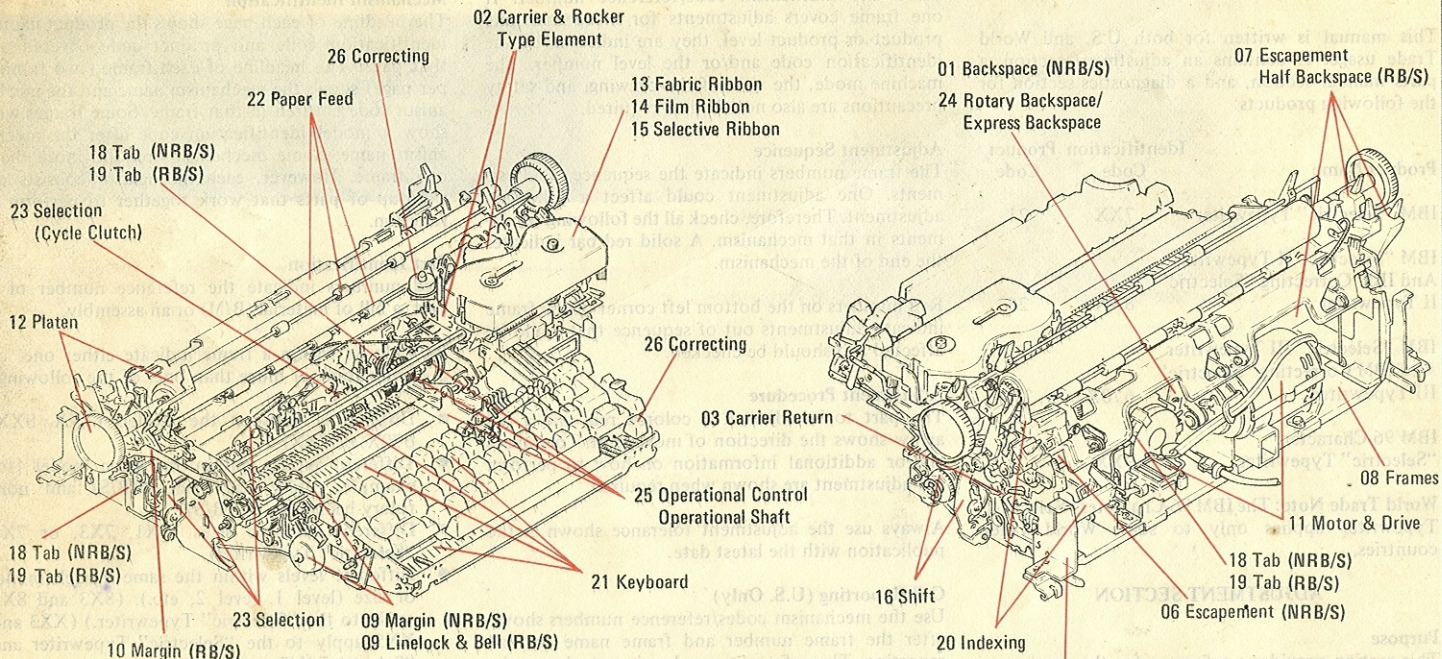

- Covers & Mountings . . . . . 04/05
- Sound Reduction . . . . . 30
- Special Features . . . . . 39 Thru 51
- Packing Parts & Inst. . . . . 65

- 04 Covers &
- 05 Mountings

• World Trade applications or differences

• Field replacement parts

• Bill of material (BOM) or assemblies (shown with a description — part shown in the drawing)

• If different levels exist, which can be used for models, modes or sizes, only the lowest level is shown in the drawing. However, the part number once list manual will show all levels.

The section contains the mechanism name and identification code and the name of the part. Each part must be used with a separate part number (not included in this manual) which contains reference number, part number, part description and price.

Introduction

The section provides a reference for the part number of the mechanism. Refer to the part number for the frame number and frame name. Always use the mechanism reference number shown in the list data for additional information.

The frame number indicates the series of the mechanism. The frame number is shown in the bottom left corner of the mechanism cover. The frame number could affect the adjustment. Therefore, check all the following items in that mechanism:

• The mechanism cover and the name of the mechanism.

• The identification code and the name of the product level (e.g., 7XX and 8XX).

• The part number of the mechanism cover. The part number is indicated by a black frame number in the top left corner.

Adjustment Identification

The heading of each page shows the product name, identification code, product code and the name of the mechanism. Refer to the part number of the mechanism cover on this page. Each adjustment is indicated by a black frame number in the top left corner.

IBM "SELECTRIC" TYPEWRITER

CONTENTS

(Alphabetical)

PARTS			ADJUSTMENTS		
Mech Code	Page	Mechanism	Frame	Page	
<b>INTRODUCTION . . . . . 1</b>					
<i>Backspace</i>					
24 . . . 89		Express Backspace . . . . .	184 .	28	
07 . . . 68		Half Backspace . . . . .	179 .	27	
01 . . . 61		Non-Rotary Backspace (NRB/S) . . . . .	163 .	26	
24 . . . 89		Rotary Backspace (RB/S) . . . . .	167 .	26	
62 . . . Cardholder Chart					
02 . . . 61		Carrier . . . . .			
03 . . . 64		Carrier Return . . . . .	151 .	23	
23 . . . 88		Character Selection . . . . .	55 .	11	
Character Selection (Rotate Tool) . . . . . 67 . 13					
Character Selection (Typehead) . . . . . 75 . 14					
26 . . . 91		Correcting . . . . .	311 .	44	
04 . . . 65		Covers & Mountings (7XX) . . . . .	359 .	50	
05 . . . 66		Covers & Mountings (8XX, 9XX) . . . . .	359 .	50	
05 . . . 67		Covers (670X) . . . . .	359 .	50	
06 . . . 68		Escapement (NRB/S) . . . . .	85 .	15	
07 . . . 68		Escapement (RB/S) . . . . .	85 .	15	
Fine Alignment . . . . . 43 . 9					
08 . . . 69		Frames . . . . .			
20 . . . 82		Indexing . . . . .	246 .	37	
20 . . . 83		Indexing (Double) . . . . .	369 .	52	
20 . . . 83		Indexing (W.T.) . . . . .	246 .	37	
21 . . . 84		Keyboard . . . . .	12 .	6	
21 . . . 85		Keyboard (Dual Impression) . . . . .	11 .	6	
09 . . . 71		Linelock & Bell . . . . .	340 .	48	
09 . . . 70		Margins (NRB/S) . . . . .	340 .	48	
10 . . . 71		Margins (RB/S) . . . . .	340 .	48	
11 . . . 75		Motor & Drive (Canadian) . . . . .	1 .	5	
11 . . . 73		Motor & Drive (Netherlands) . . . . .	1 .	5	
11 . . . 72		Motor & Drive (U.S.) . . . . .	1 .	5	
25 . . . 90		Operational Control . . . . .	118 .	20	
25 . . . 90		Operational Shaft Assembly . . . . .			
22 . . . 86		Paper Feed ("A-Frame") . . . . .	234 .	35	
22 . . . 86		Paper Feed (Tie-Rod) . . . . .	234 .	35	
12 . . . 76		Platen . . . . .			
Print . . . . . 213 . 32					
13 . . . 76		Ribbon, Fabric . . . . .	278 .	41	
14 . . . 77		Ribbon, Film . . . . .	262 .	38	
15 . . . 78		Ribbon, Selective . . . . .	291 .	42	

PARTS			ADJUSTMENTS		
Mech Code	Page	Mechanism	Frame	Page	
02 . . . 63		Rocker (Gear Type Tilt) . . . . .			
02 . . . 63		Rocker (Gearless Type Tilt) . . . . .			
23 . . . 88		Selection . . . . .			
16 . . . 78		Shift . . . . .	32 .	8	
17 . . . 79		Spacebar . . . . .	126 .	22	
18 . . . 80		Tab (NRB/S) . . . . .	190 .	29	
19 . . . 81		Tab (RB/S) . . . . .	190 .	29	
02 . . . 63		Type Elements . . . . .			
<b>FEATURES</b>					
39 . . . 93		Cardholding Platen . . . . .			
40 . . . 93		Dead Key (U.S.) . . . . .	363 .	51	
40 . . . 94		Dead Key (W.T.) Thailand . . . . .			
40 . . . 93		Dead Key Disconnect . . . . .	366 .	51	
13 . . . 76		External Ribbon Control . . . . .	376 .	52	
45 . . . 95		Handicapped Attachments . . . . .			
21 . . . 84		Manual Velocity Control . . . . .	378 .	53	
49 . . . 97		Overhead Pin Feed Platen (W.T.) . . . . .			
49 . . . 96		Pin Feed Platen . . . . .	381 .	53	
41 . . . 94		Shift Sensing (Dual Impression) . . . . .	386 .	54	
30 . . . 92		Sound Reduction . . . . .			
51 . . . 97		Stroke Counter . . . . .			

PARTS			ADJUSTMENTS		
Mech Code	Page	Mechanism	Frame	Page	
<b>GENERAL INFORMATION</b>					
Broken Tapes Check . . . . . 55					
Cause Of Failure Codes . . . . . Inside Rear Cover					
Common Abbreviations . . . . . 4					
Correcting Diagnostics . . . . . 57					
Functional Check . . . . . 55					
Identification Codes . . . . . Inside Rear Cover					
Lubrication Guide . . . . . 54					
Ribbon Applications . . . . . 56					
Safety Precautions . . . . . Inside Front Cover					
Service Call Procedure . . . . . 54					
Type Element Arrangement . . . . . 56					
Voltage Checks "Selectric" III . . . . .					
Dual-Pitch Typewriter . . . . . 58					
Wiring Diagrams . . . . . 60					
<b>BOLT DOWN PARTS AND INSTRUCTIONS</b>					
93 . . Bolt Down Instructions					
04 . . . 60		Bolt Down Parts (7XX) . . . . .			
05 . . . 61		Bolt Down Parts (8XX, 9XX, 670X) . . . . .			
<b>PACKING PARTS AND INSTRUCTIONS</b>					
65 . . . 100		Packing (U.S.) . . . . .			
65 . . . 98		Packing (W.T.) . . . . .			
<b>CHARTS</b>					
Cardholder Chart . . . . . 62					
04 . . . . .		*Painted Cover Parts (7XX)			
05 . . . . .		*Painted Covers Parts (8XX, 9XX)			
12 . . . . .		*Platen Indexing			
*These charts are printed in the Part Number/Price List (P/N 241-5103).					

(Introduction Continued From Page 1)

Some parts are shown for assembly purposes only and do not show a reference number. Replace these parts by ordering either the assembly or a later level part.

#### Parts Ordering

Locate the mechanism in which the part functions by using the contents page. Note the mechanism code, find the part in the drawing, and note the reference number. Use this mechanism code/reference number to locate the part number and price in the part number/price list manual.

World Trade should use the country's procedures to find the prices.

Features and devices (MESs) or specification changes (SERs) desired by the customer must be ordered through CE management and Branch Office sales.

Replacement parts for features, devices and SERs not shown in the parts manual must also be ordered through CE management and Branch Office sales.

### COMMON ABBREVIATIONS

The following list is provided as a reference for some of the common abbreviations used in this manual. It should be noted that some of these are new since the last revision.

APM	Adjustment Parts Manual
ASM	Assembly
AVC	Automatic Velocity Control
B/M	Bill Of Material
CC	Cycle Clutch
CR	Carriage Return
CSI	Combined Service Information
DI	Dual Impression
DP	Dual Pitch
ECC OT	Eccentric Index Overthrow Stop
FI	Field Installable
FTB	Floating Torque Bar
g	Grams
mm	Millimeters
NRB/S	Non-Rotary Backspace
PN/PL	Part Number/Price List
Pre-DI	Pre-Dual Impression
Pre-FTB	Pre-Floating Torque Bar
RB/S	Rotary Backspace
SB	Spacebar
SER	Special Engineering Request
SHP	Shop Manual 241-6670
SP	Single Pitch
TII	Technical Information Index
TYP	Type Catalog 241-5687
UBS	Upper Ball Socket
W.T.	World Trade

**1 Cycle Shaft End Play (23-421)**

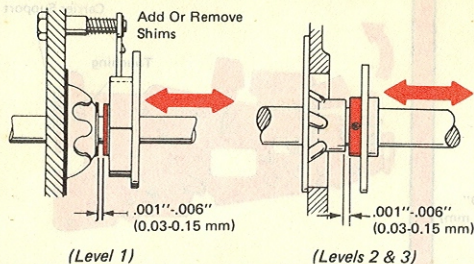

**2 Gear Train Backlash (23-461)**

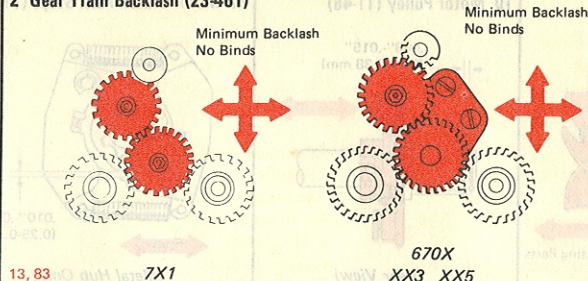

**3 Cycle Clutch Latch Bracket (21-532)**

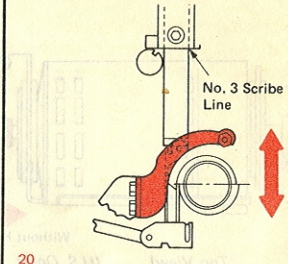

**4 Cycle Clutch Spring (23-404)**

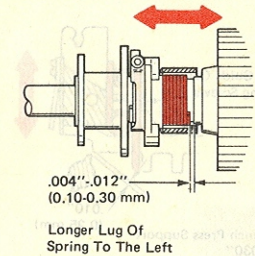

**5 Cycle Clutch Sleeve End Play (23-409)**

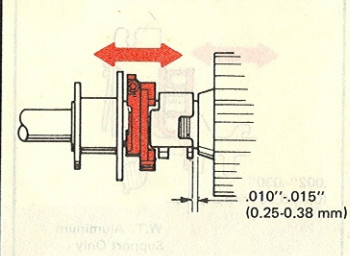

**6 Cycle Clutch Drive (23-404)**

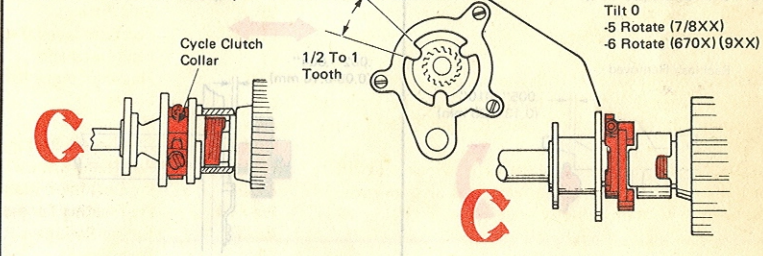

**7 Cycle Clutch Overthrow (23-412)**

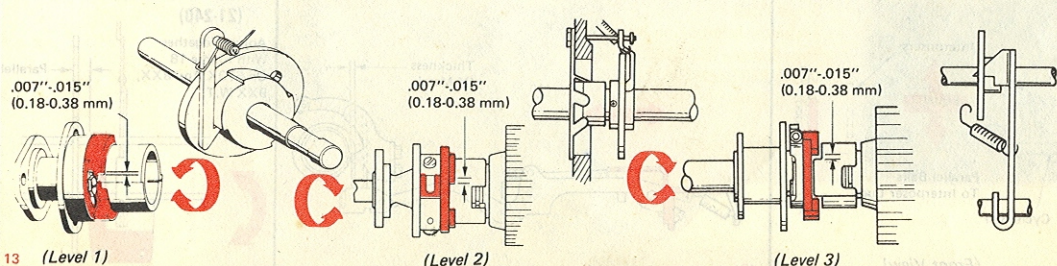

**8 Drive Belt (11-68)**

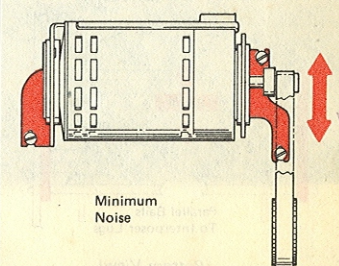

9 Motor Fan (11-400)

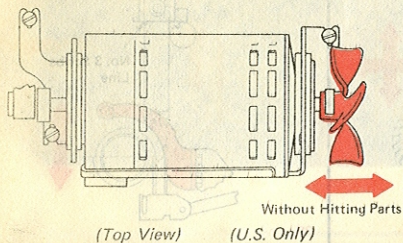

10 Motor Pulley (11-48)

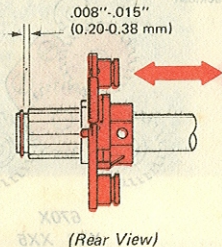

11 Motor Clutch Pawl Stops (11-43)

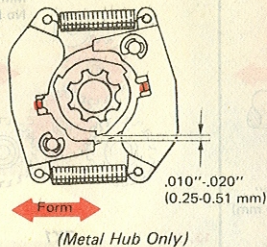

12 Keyboard Position (21-100)

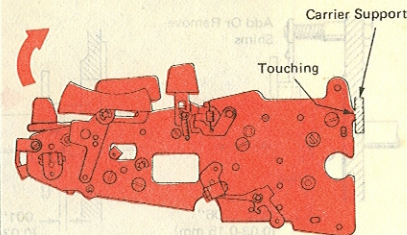

13 Filter Shaft (21-114)

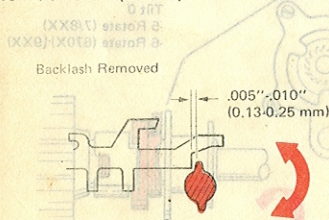

40, 108, 145, 232

14 Filter Shaft End Play (21-121)

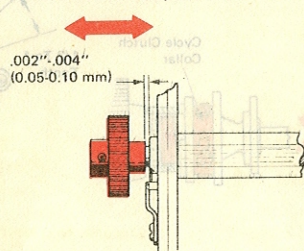

15 Rear Bearing Support (21-06)

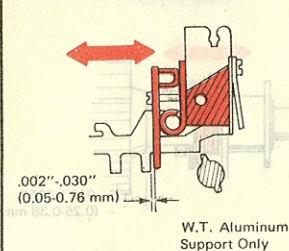

21, 22, 23

16 Rear Interposer Guide Comb (21-29)

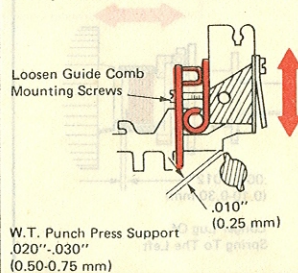

17 Bail Mounting Plate (21-303)

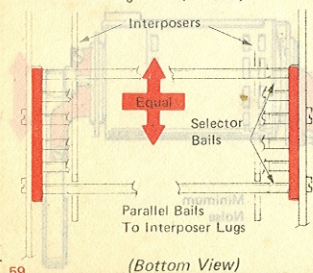

59

18 Keeper Bracket (21-204)

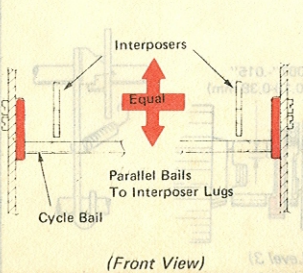

42

19 Cycle Bail Damper Spring (21-240)

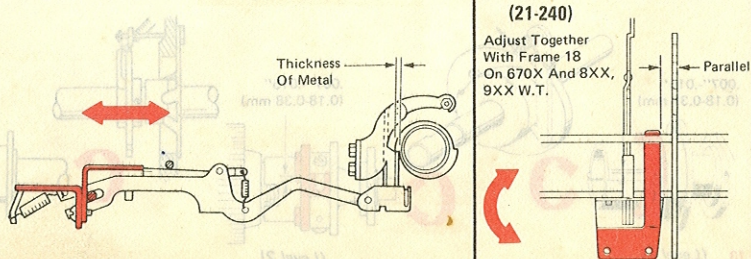

20 Cycle Clutch Latch Restoring (21-206)

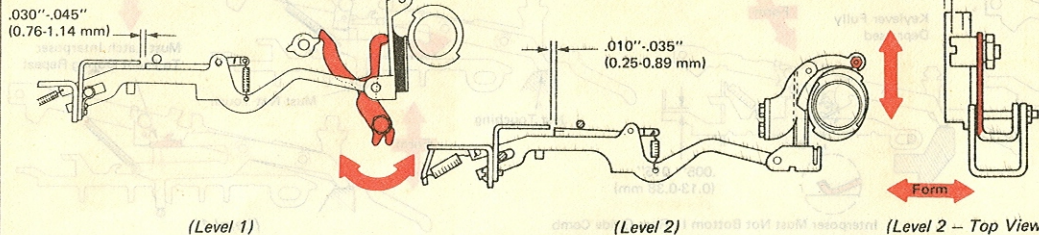

21 Interposer Latch Springs (21-4)

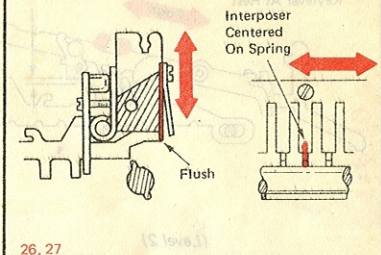

22 Cycle Clutch Keeper (21-205)

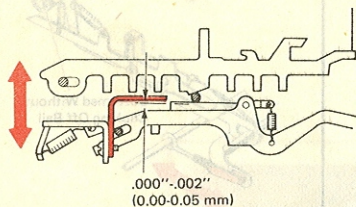

23 Cycle Bail Upstop (21-208)

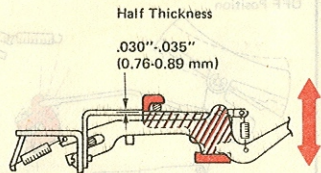

24 Front Keylever Guide Comb (21-132)

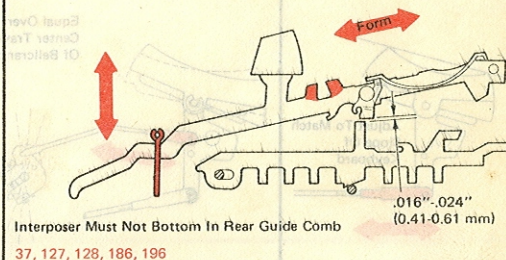

25 Compensator Tube (21-28)

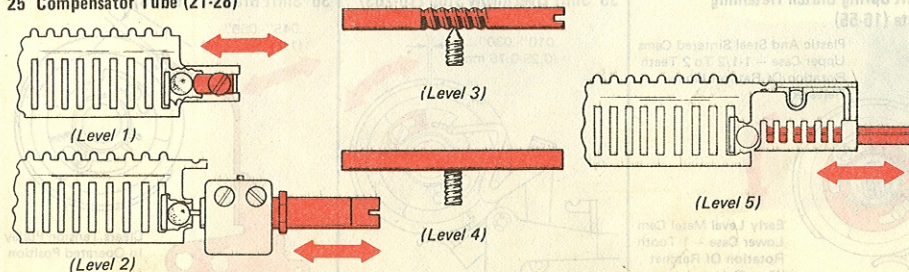

26 Typamatic Keylever (21-109)

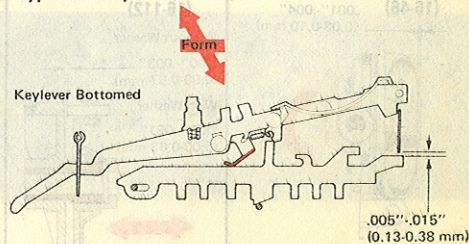



27 Repeat Keylever (21-106)

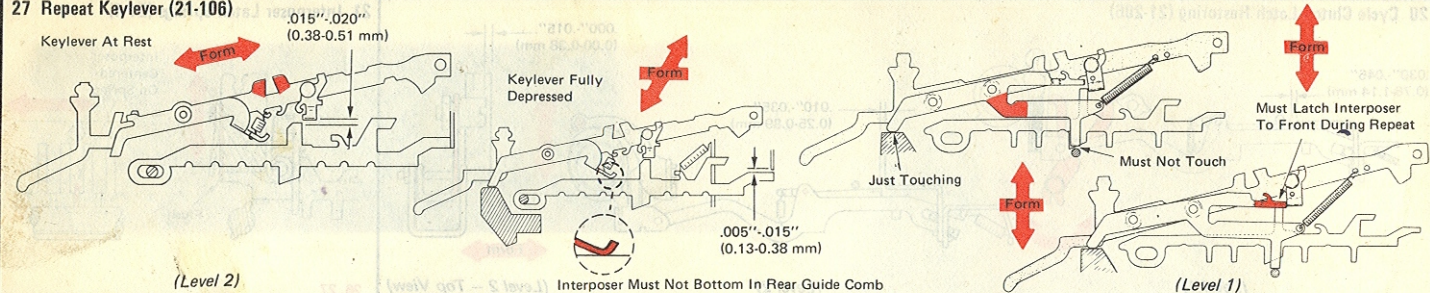

28 Switch Link (21-709)

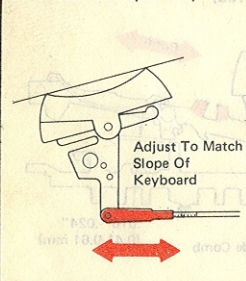

29 Lockout Bail Link (21-546)

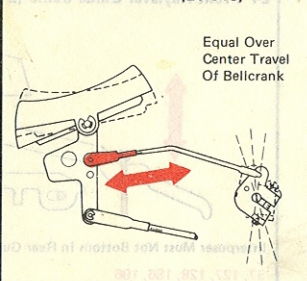

30 Lockout Bail Bellcrank (21-553)

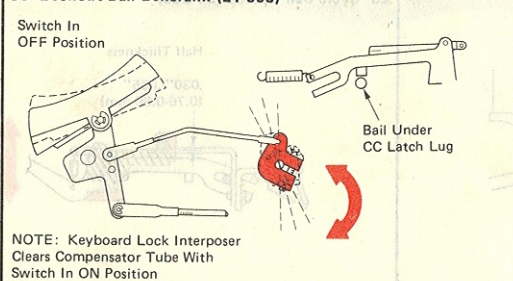

31 Keyboard Lock Bellcrank Link (21-305)

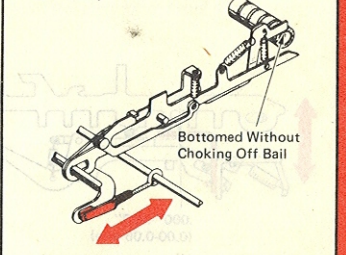

32 Shift Cam Backup Roller (16-46)

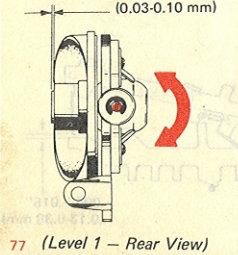

33 Shift Cam Bearing (16-112)

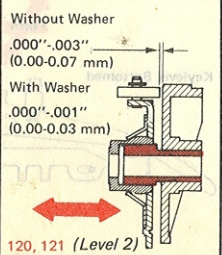

34 Shift Spring Clutch Retaining Plate (16-55)

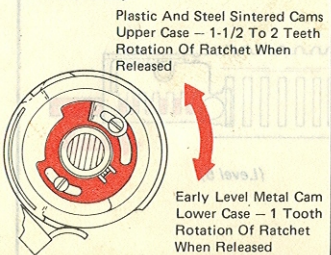

35 Shift Overthrow Stop (16-203)

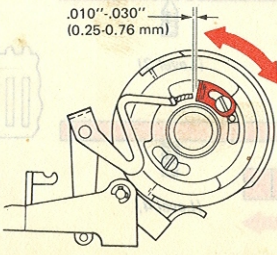

36 Shift Bracket (16-208)

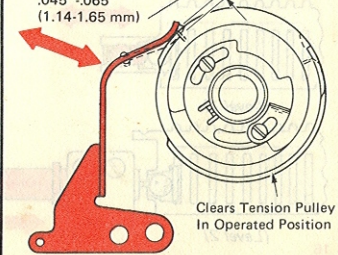

37 Shift Release (16-19)

Equal Over Center Travel

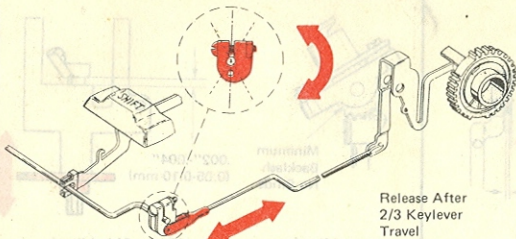

Release After  
2/3 Keylever  
Travel

38 Shift Lock (16-37)

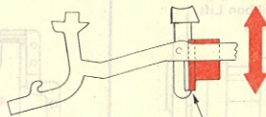

Adjust To Lock  
Just As Shift  
Clutch Operates

39 Shift Interlock (16-73)

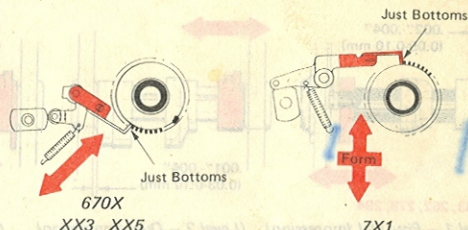

40 Shift Interlock Cam (16-14)

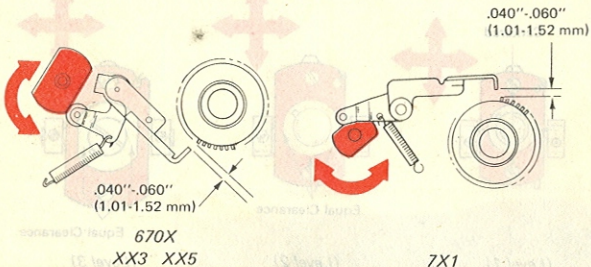

670X  
XX3 XX5

7X1

41 Character Interrupter (21-285)

Cycle Clutch  
Latch Link  
Released  
Forward

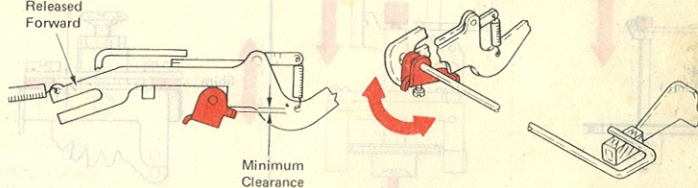

Minimum  
Clearance

42 Character Interrupter Bracket (21-287)

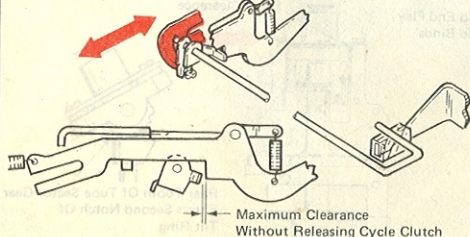

Maximum Clearance  
Without Releasing Cycle Clutch

43 Carrier Shoe (02-107)

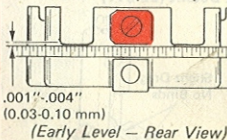

(Early Level - Rear View)

(02-119)



(02-112)

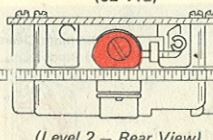

(Level 2 - Rear View)

(02-96)

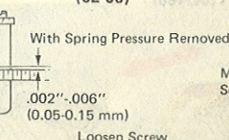

(Level 3 - Rear View)

With Spring Pressure Removed

Machines With RB/S  
See Frame 92

Loosen Screw

Parallel To Rear Support

Parallel With Pawl Centered  
In Escapement Rack

44 Print Sleeve End Play (02-152)

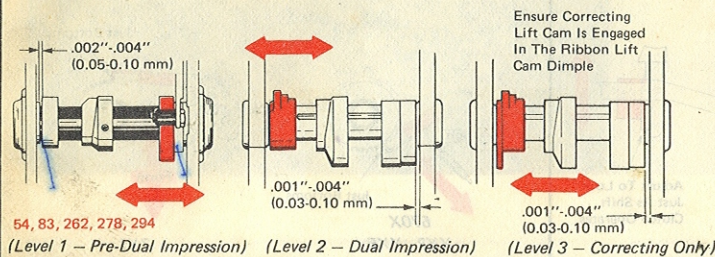

45 Rocker End Play (02-530)

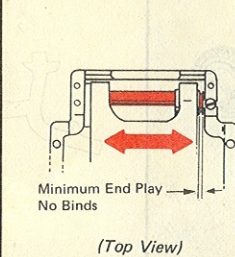

46 Tilt Tube End Play (02-305)

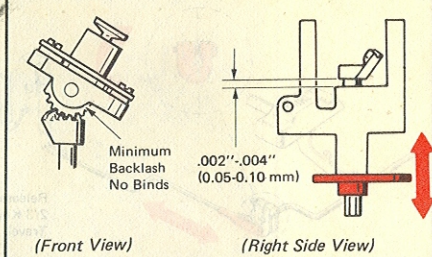

47 Rotate Shaft End Play (02-415)

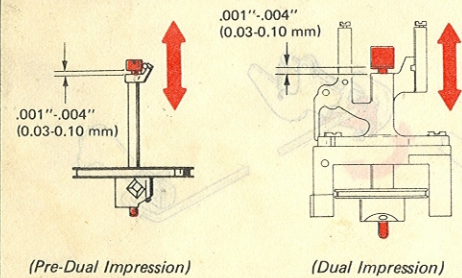

48 Upper Ball Socket (02-400)

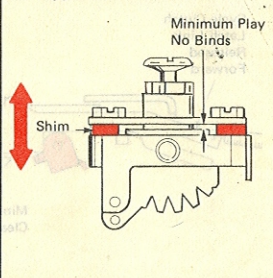

49 Tilt Ring Spacer (02-402)

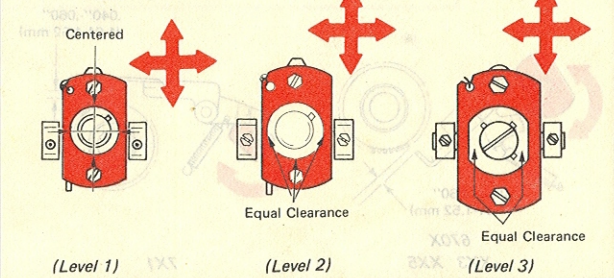

50 Rotate Detent (02-406)

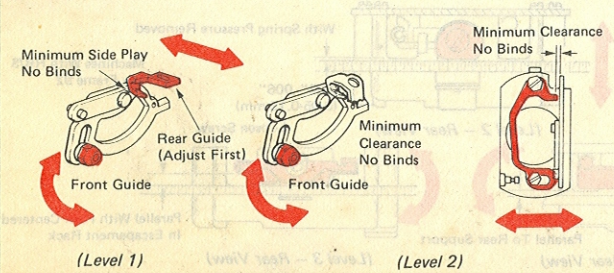

51 Tilt Detent (02-311)

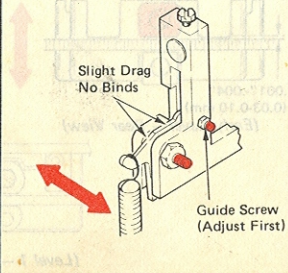

52 Tilt Ring Pivot Pins (02-300)

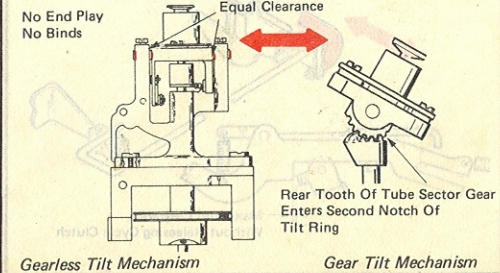

**53 Detent Cam Follower Bracket (02-501)**

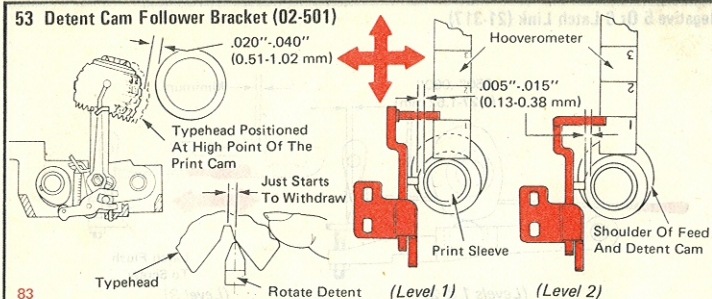

**54 Skirt Clearance (02-505)**

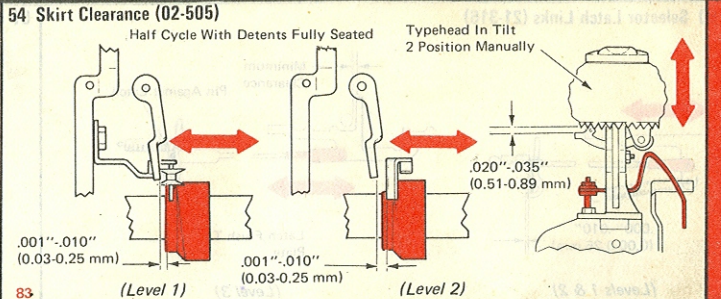

**55 Print Shaft Timing (Preliminary) (02-30)**

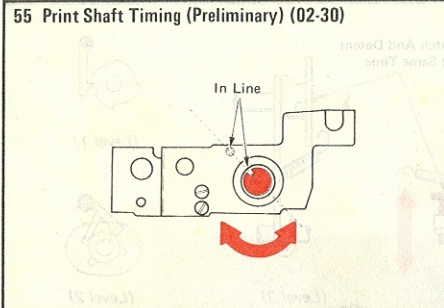

**56 Latch Bail Shaft (23-115)**

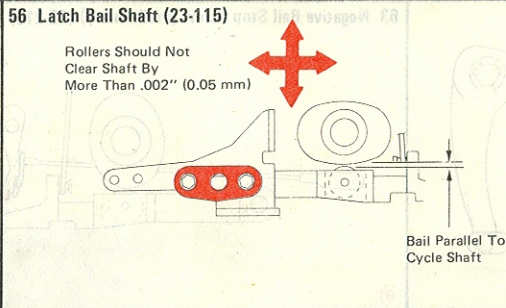

**57 Differential Guides (23-207) (23-34)**

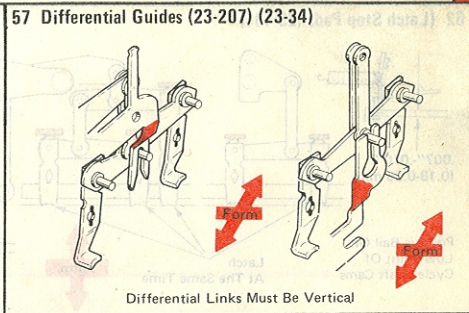

**58 Positive Latch Bail Guide (23-107)**

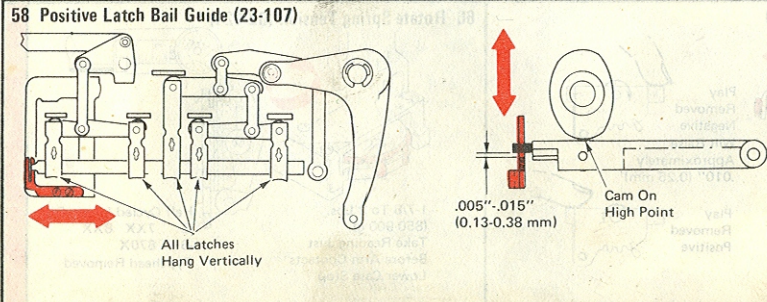

**59 Interposer Stop Lugs (21-310) (21-325)**

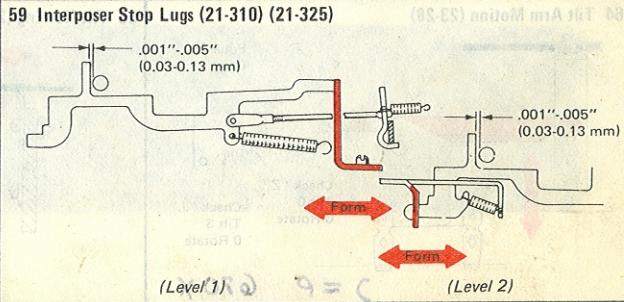

60 Selector Latch Links (21-316)

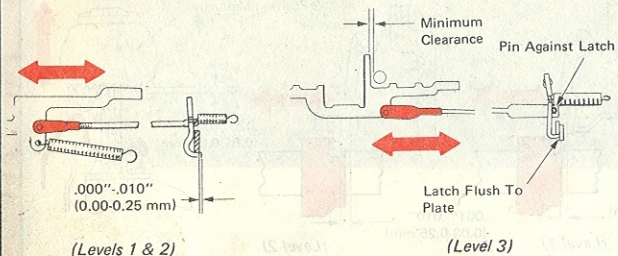

61 Negative 5 Or 6 Latch Link (21-317)

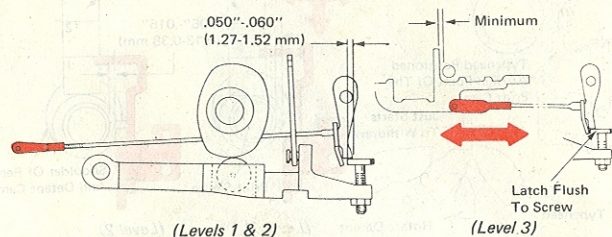

62 (Latch Stop Pads (23-486)

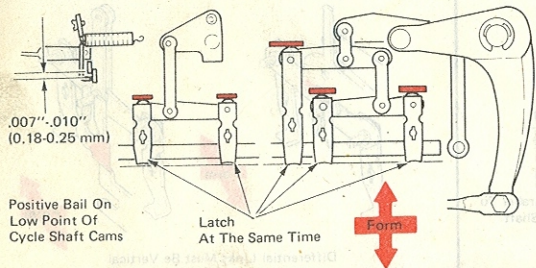

63 Negative Bail Stop Screw (Preliminary) (23-216)

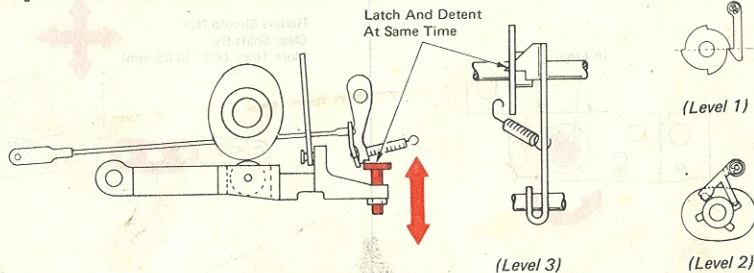

64 Tilt Arm Motion (23-28)

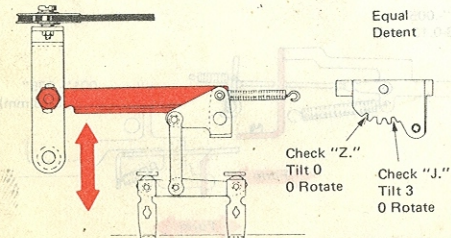

65 Tilt Homing (23-007)

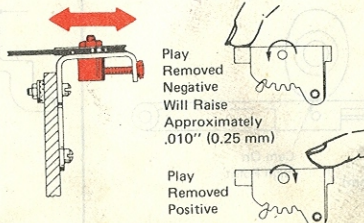

66 Rotate Spring Tension (02-424)

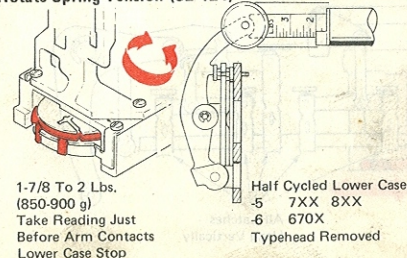

2 = P 670X

**67 Compensator Arm (23-363)**

Compensator Arm Must Be Disabled. See Service Manual

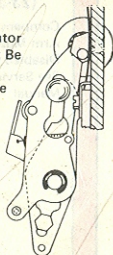

**68 Rotate Arm Vertical (Preliminary) (23-367)**

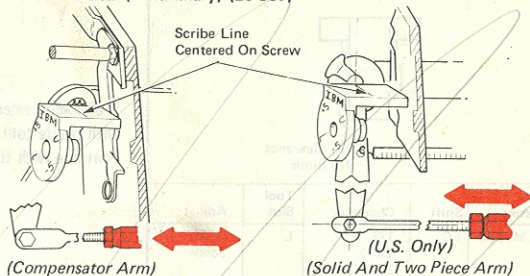

**69 Preliminary Homing (02-420)**

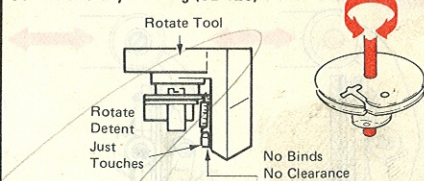

Adjustment	Shift	Character	Tool Slot	Adjust
Preliminary Homing	UC	1 Tilt 2 +3 Rotate	U	Rotate Pulley W.T. L-2/UBS

**70 Zero Rotate (23-228)**

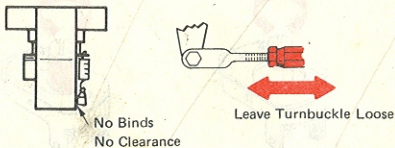

Adjustment	Shift	Character	Tool Slot	Adjust
Zero Rotate	UC	1/4 Tilt 2 Zero Rotate	U	Turnbuckle W.T. L-2/UBS

**71 Positive 5 Motion (23-369)**

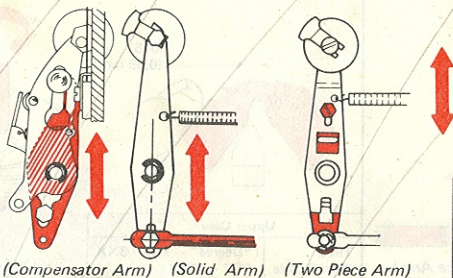

Adjustment	Shift	Character	Tool Slot	Adjust
+5 Motion	UC	W Tilt 2 +5 Rotate	+5	Rotate Arm

**72 Negative 5 Motion (23-369)**

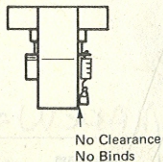

Adjustment	Shift	Character	Tool Slot	Adjust
-5 Motion	UC	M Tilt 2 -5 Rotate	-5	Turnbuckle W.T. L-2/UBS

**73 Balance (Final) (23-216)**

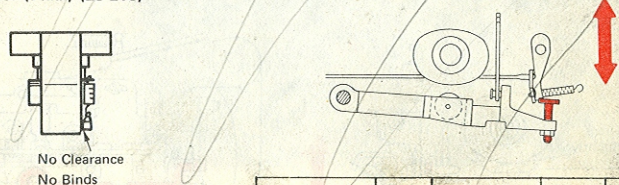

Adjustment	Shift	Character	Tool Slot	Adjust
Balance	UC	1/4 Tilt 2 Zero Rotate	U	-5 Stop Screw

74 Shift Motion (16-101) (16-41)

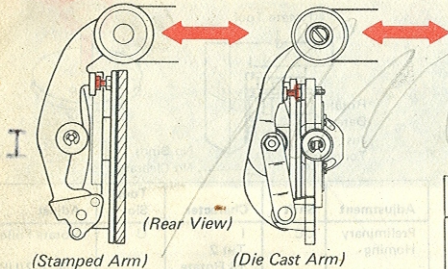

Adjustment	Shift	Character	Tool Slot	Adjust
Shift Motion	LC	1/2 Tilt 2 Zero Rotate	L	Shift Stop Screw

If character selection adjustments with rotate tool are complete, continue with frame 83.

75 Compensator Arm (23-363)

Compensator Arm Must Be Disabled See Service Manual

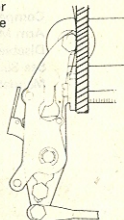

76 Rotate Arm Vertical (Preliminary) (23-367)

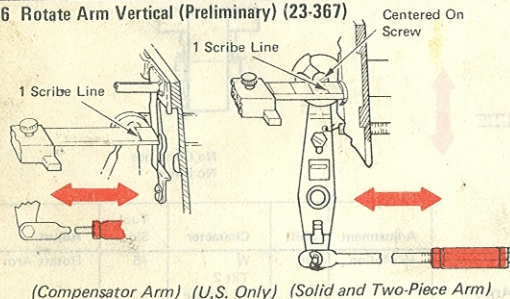

77 Typehead Homing (Preliminary) (02-420)

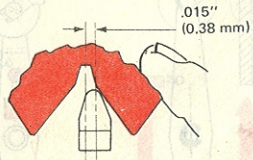

Upper Case	
Tilt 2	"Degree" - 7XX 8XX
Zero Rotate	"R" - 670X



7XX 8XX

(02-441)

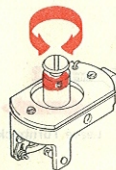

670X  
9XX W.T.

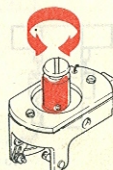

8XX W.T.

78 Negative 6 Upstop (23-241)

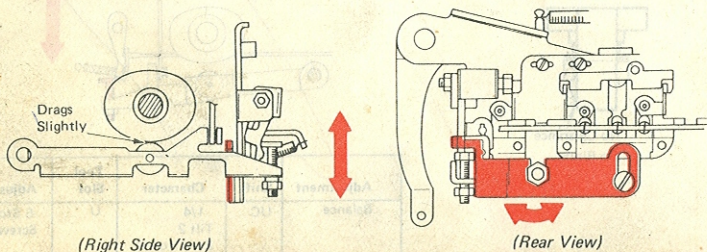

79 Rotate Arm Motion (23-369)

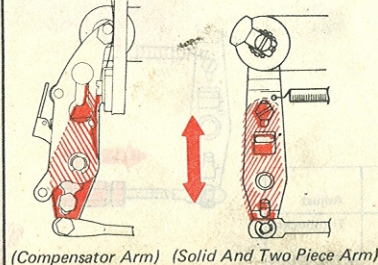

MAKEW=T

Upper Case	
"Degree" = "W"	7XX 8XX
"R" = "V"	670X
Tilt 2	Tilt 2
Zero Rotate	+5 Rotate
	7XX 8XX
	670X 9XX

**80 Balance (Final) (23-216)**

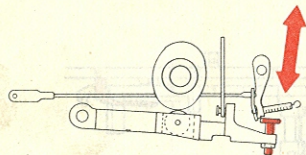

MAKE THEM

7XX 8XX	670X 9XX W.T.
"T" = "M"	"R" = "degree"
Tilt 1 Zero Rotate = -5 Rotate	Tilt 2 Zero Rotate = -6 Rotate

(Adjustable Balance Arm)

**81 Typehead Homing (Final) (02-420)**

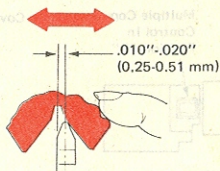

7XX 8XX

**(02-441)**

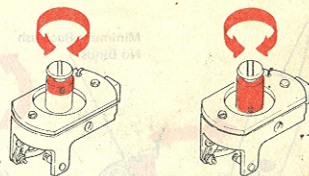

670X  
9XX W.T.

8XX W.T.

Upper Case			
Tilt 2 Zero Rotate	"Degree"	7XX 8XX	670X

**82 Shift Motion (16-101)**

**(16-41)**

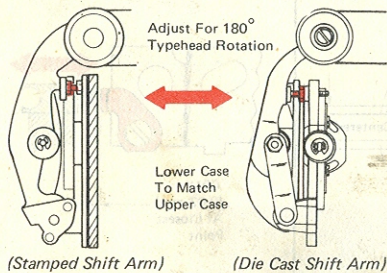

Adjust For 180°  
Typehead Rotation.

Lower Case  
To Match  
Upper Case

(Stamped Shift Arm)

(Die Cast Shift Arm)

**83 Fine Timing (02-30)**

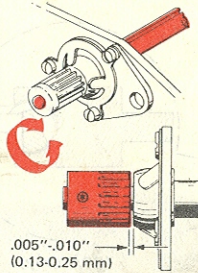

.005"-.010"  
(0.13-0.25 mm)

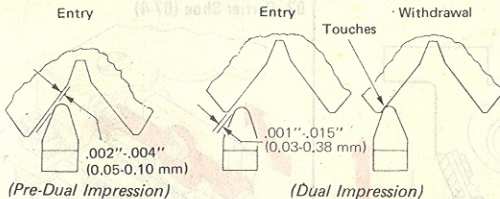

(Pre-Dual Impression)

(Dual Impression)

Hand Cycle Upper Case M	Tilt 2 -5 Rotate	7XX 8XX
Hand Cycle Upper Case Degree	Tilt 2 -6 Rotate	670X 9XX W.T.

**84 Rotate Pulley Guard (23-351)**

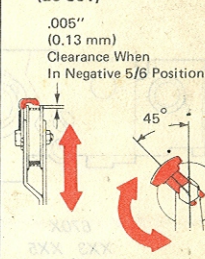

.005"  
(0.13 mm)  
Clearance When  
In Negative 5/6 Position

45°

**85 Escapement Rack Or Rail (07-11)**

Hoovermeter On Number One Scribe Line

Just Spans The Distance

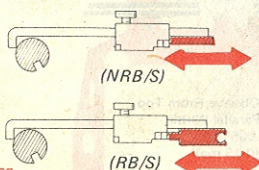

165  
Check At Left, Center, And Right

**86 Escapement Rack Guide (07-20)**

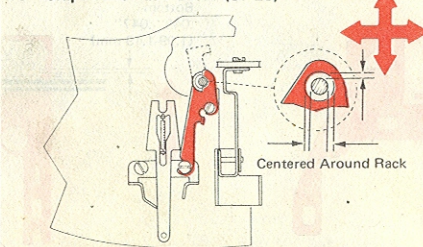

Centered Around Rack

89 (Dual Pitch Only) (Left Side View)

**87 Escapement Rack Teeth Vertical (07-23)**

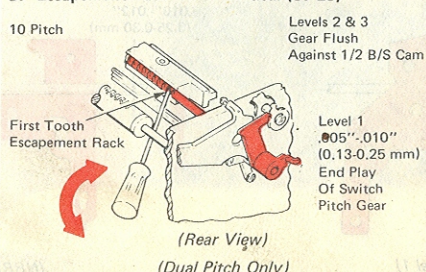

10 Pitch

Levels 2 & 3  
Gear Flush  
Against 1/2 B/S Cam

First Tooth  
Escapement Rack

Level 1  
.005"-.010"  
(0.13-0.25 mm)  
End Play  
Of Switch  
Pitch Gear

(Rear View)  
(Dual Pitch Only)

**88 Escapement Rack Gear Lower Stop (07-20)**

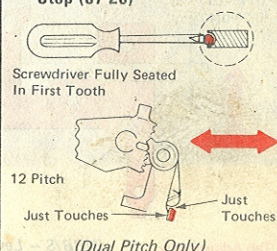

Screwdriver Fully Seated  
In First Tooth

12 Pitch

Just Touches  
Just Touches  
(Dual Pitch Only)



89 Switch Pitch Sector Gear (07-31)

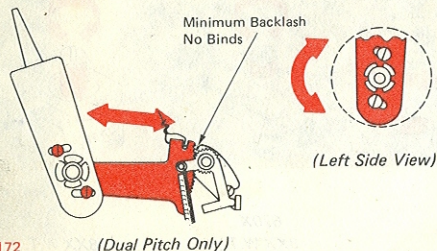

172

7XX 8XX 9XX

Clears Covers In Both Pitches Equally

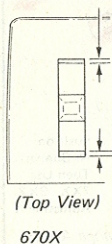

90 Escapement Pawl Guide Lug (07-4)

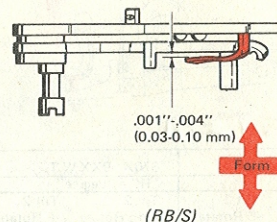

91 Carrier Support (02-8)

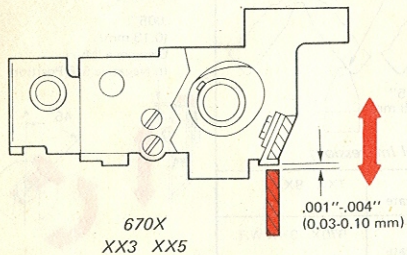

92 Carrier Shoe (07-4)

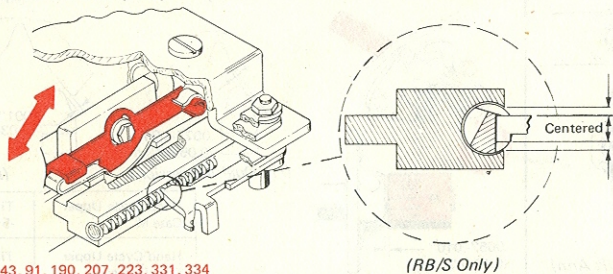

93 Carrier Buffer (02-130)

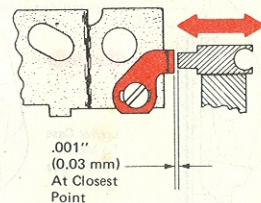

94 Escapement Bracket (06-23)

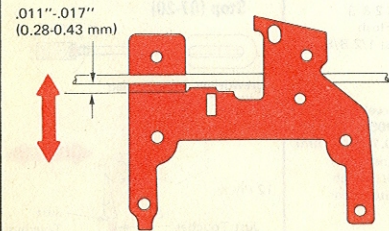

Tab Adjustments

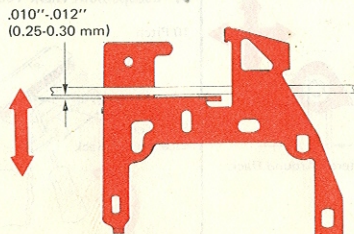

(NRB/S - Level 2)

Observe From Bottom  
.043"-.047"  
(1.09-1.19 mm)

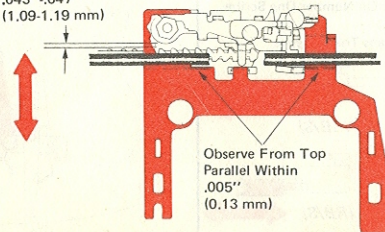

(RB/S - Level 3)

**95 Torque Bar (Preliminary) (06-029)**

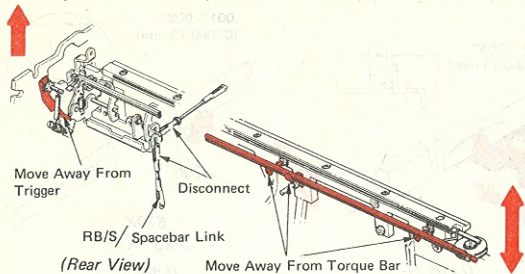

(Rear View)

Move Away From Trigger Bracket

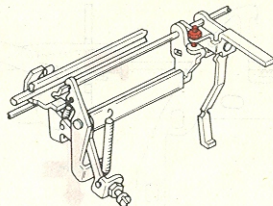

(NRB/S)

**96 Escapement Torque Bar (06-33)**

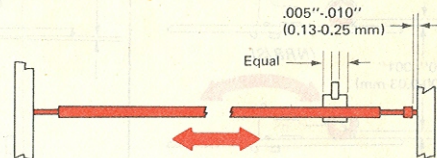

(NRB/S - Level 1)

**97 Pawl Mounting Stud (Preliminary) (06-26)**

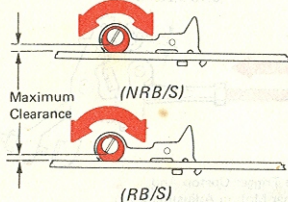

(Bottom View - Level 1)

**98 Torque Bar Upstop (Preliminary) (06-55)**

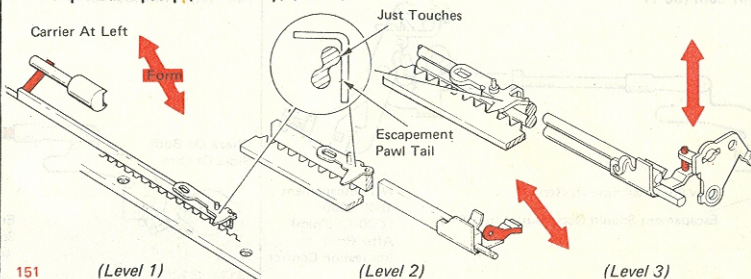

151

**99 Escapement Pawl Tail Clearance (23-50)**

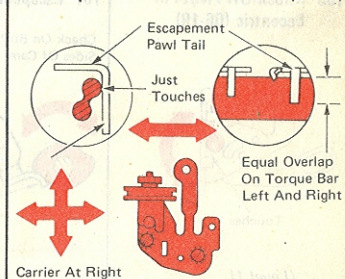

**100 Center Torque Bar Backup Screw Final (06-59)**

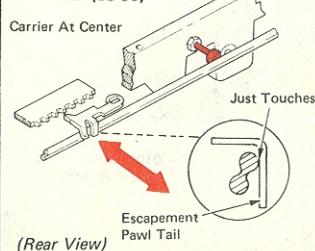

**101 Left Torque Bar Backup Screw (Final) (06-13) (07-13)**

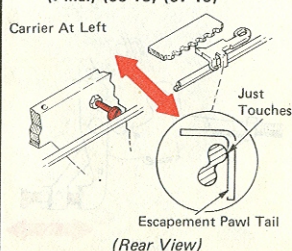

**102 Torque Bar Upstop (Final) (06-55)**

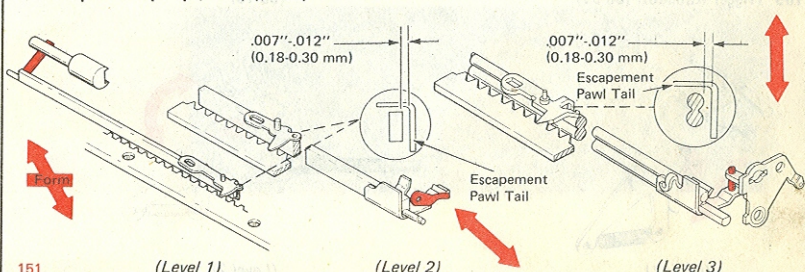

151

**103 Pawl Mounting Stud (Final) (06-26)**

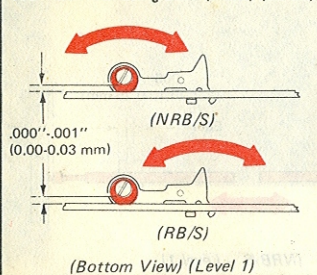

**104 Tab Torque Bar Parallel (23-50)**

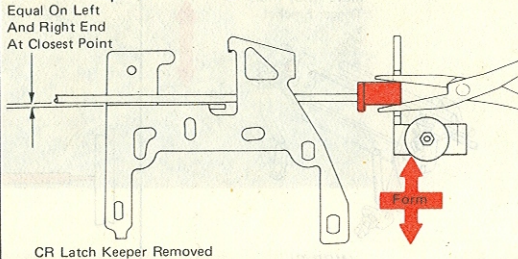

**105 Torque Bar Backstop (06-39)**

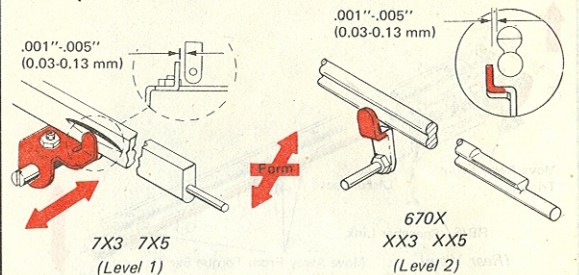

**106 Knock-Off Pivot Pin Eccentric (06-19)**

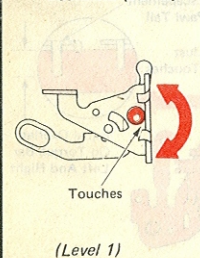

**107 Escapement Cam (06-7)**

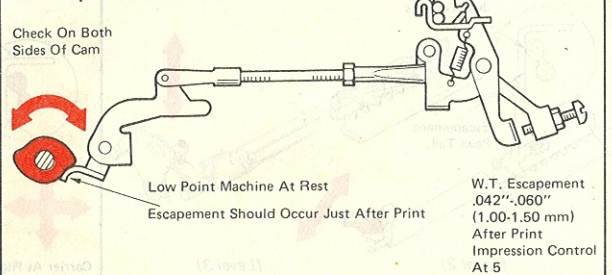

**108 Trip Link (06-10)**

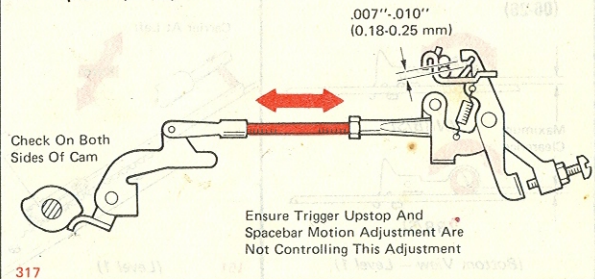

**109 Trigger Knockoff (06-51)**

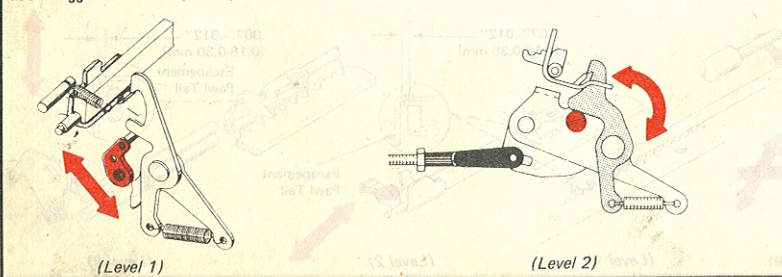

**(06-14)**

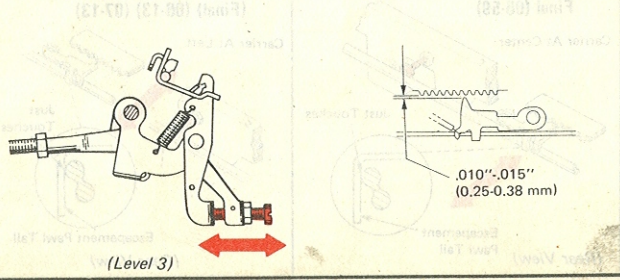

110 Trigger Upstop (Final) (06-36)

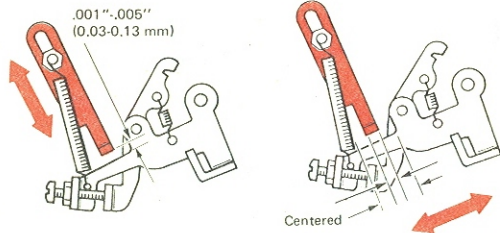

111 Spacebar Link (17-306)

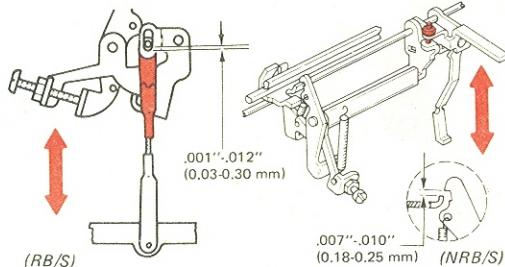

(07-40)

112 Mainspring Hub (19-13)

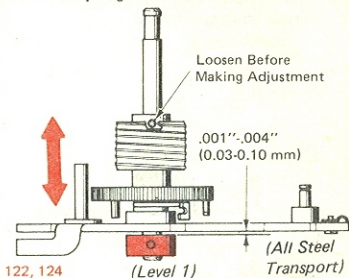

113 Escapement Shaft Collar (03-363)

(24-8)

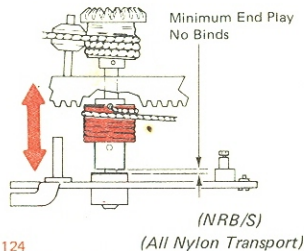

122, 124

(24-6)

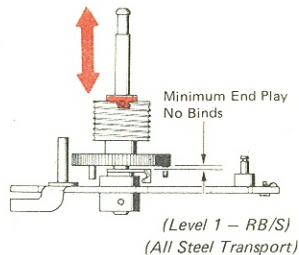

(Level 1 - RB/S)  
(All Steel Transport)

114 Mainspring (18-95)

(19-12)

This Spring Requires 5 Turns At The RH Margin

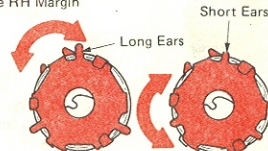

1/2-3/4 Lbs.  
(226.8-340.2 g)  
Tension As Carrier Escapes Through Extreme RH Margin

This Spring Requires 7 Turns At The RH Margin

115 Idler Pulley Eccentric (18-124) (19-16)

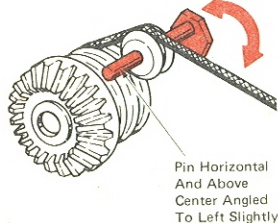

116 Cord Tension (03-363) (24-6)

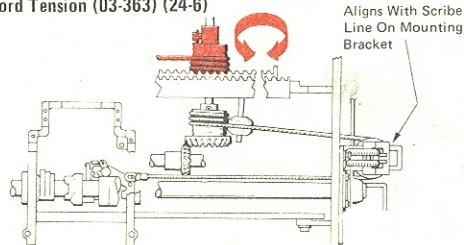

113

(NRB/S And Level 2 RB/S)

117 Cable Tension (19-23)

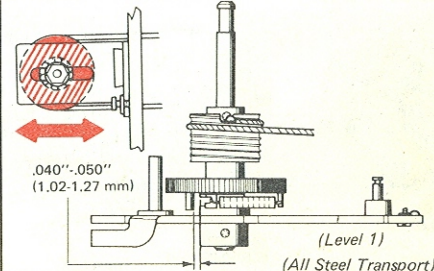

(Level 1)

(All Steel Transport)

**118 Operational Shaft Support Bracket, Front To Rear (25-350)**

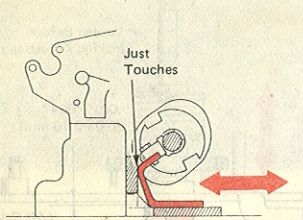

**119 Operational Shaft Support (25-56)**

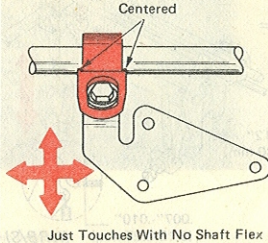

**120 Operational Shaft Position (25-24)**

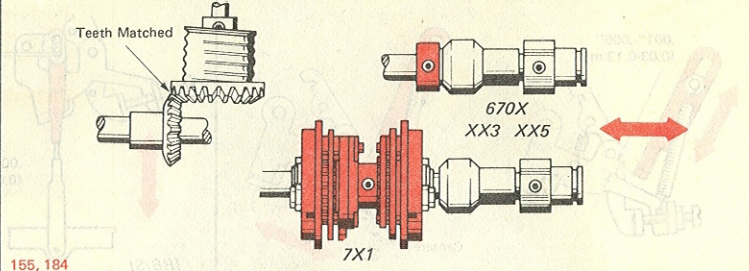

**121 Operational Shaft End Play (25-23)**

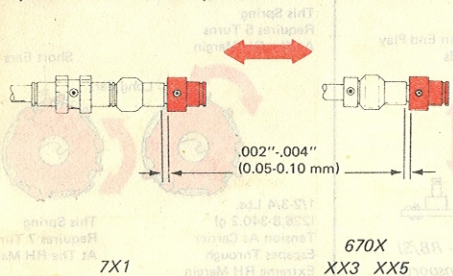

**122 CR Pinion Backlash (18-103)**

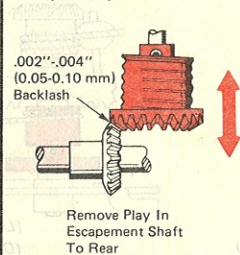

**123 CR Pinion End Play (25-3)**

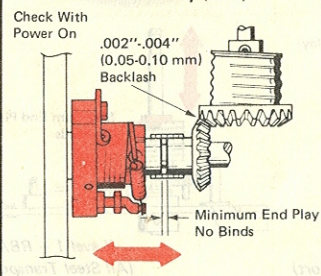

**124 Tab Pinion Backlash (25-20)**

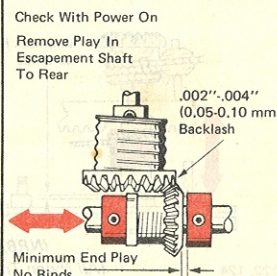

**125 Index Keylever Pawl Clearance (25-224)**

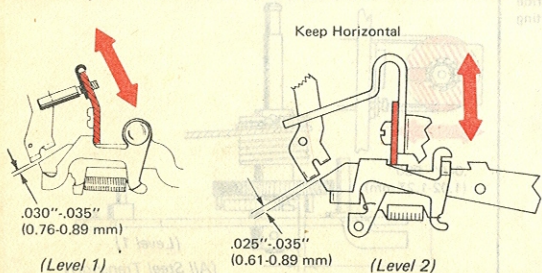

**126 Keylever Pawl Overlap (25-302) (25-238)**

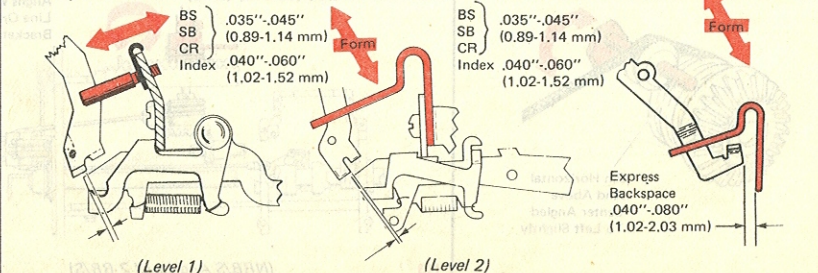

**127 Spacebar Keylever Pawl Clearance (17-110) (17-150)**

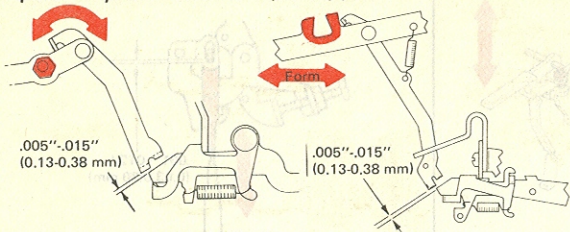

143, 144

(Level 1)

(Level 2)

**128 CR And BS Keylever Pawl Clearance (03-101)**

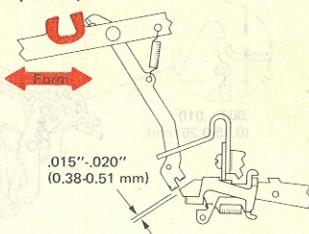

**129 Check Ring (25-29)**

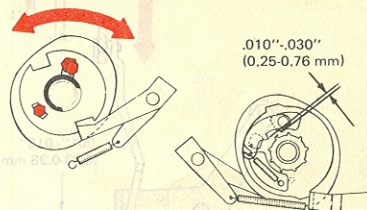

**130 Operational Cam Position (25-101)**

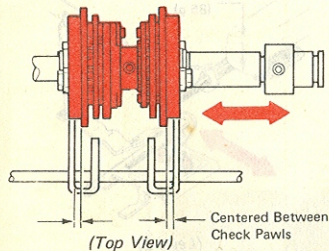

**131 Release Arm Overlap (25-205)**

Maximum Overlap Without Touching Cam

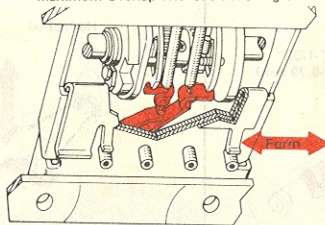

**132 Clutch Release Arm Overlap (25-205)**

NOTE: Interposer Latched Operational Cam Released Manually

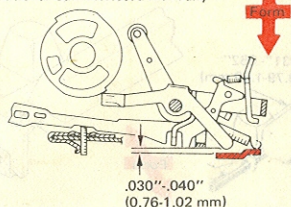

**133 Clutch Release Arm (25-205)**

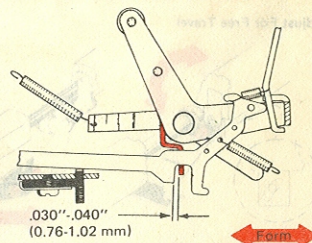

**134 Interposer Restoring Bail (25-216)**

Cam On High Point

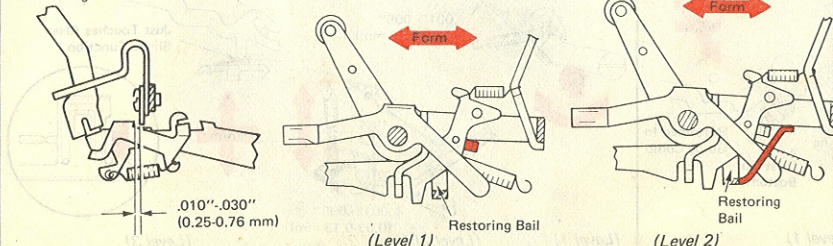

**135 Interposer Adjusting Screw (25-222)**

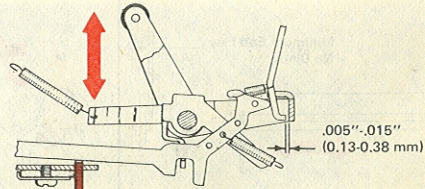

Adjust	Adjustment
1. B/S And CR	.005\"-.015\" (0.13-0.38 mm)
2. SB (RB/S Machines)	To Match B/S And CR
3. Index	To Match All Others

136 Latch Height (17-300)

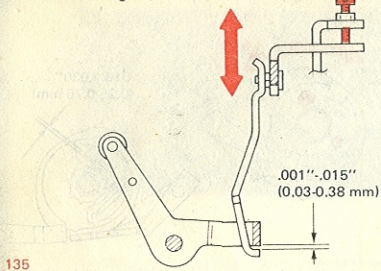

135

137 Latch Lever Screw (07-40)

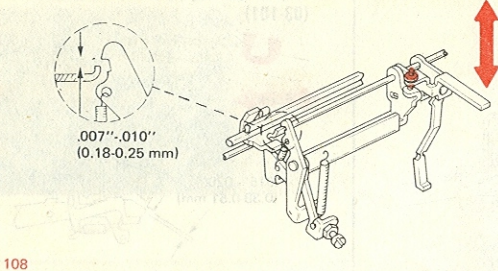

108

138 Spacebar Link (17-306)

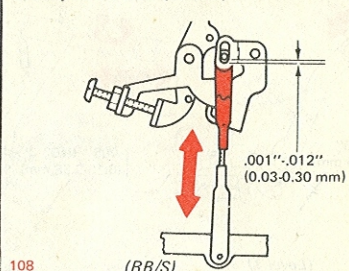

108

139 Spacebar Guide (17-129)

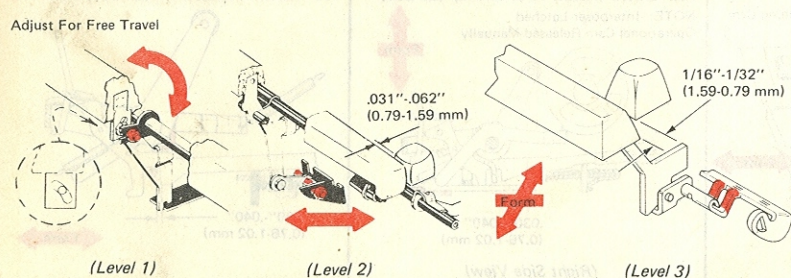

140 Spacebar Return (17-124) (17-146)

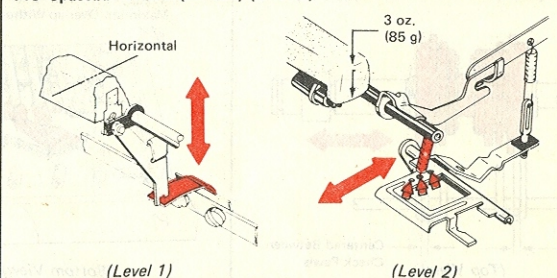

141 Spacebar Operating Arm (17-152)

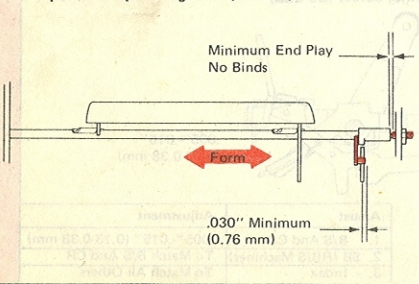

142 Spacebar Operating Cam (17-132)

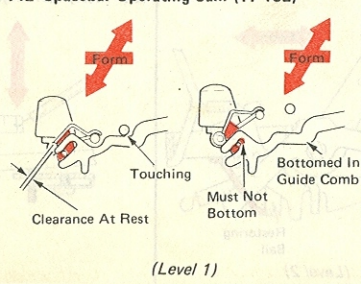

143 Repeat Stop (17-106) (17-148)

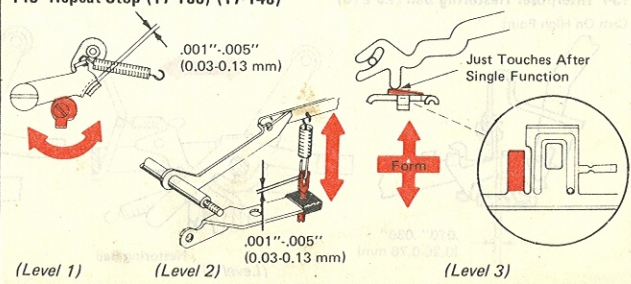

144 Spacebar Final Stop (17-119)

(21-143)

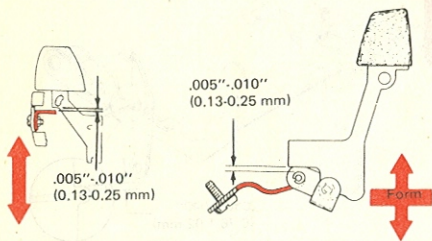

145 Interlock Cam (17-353)

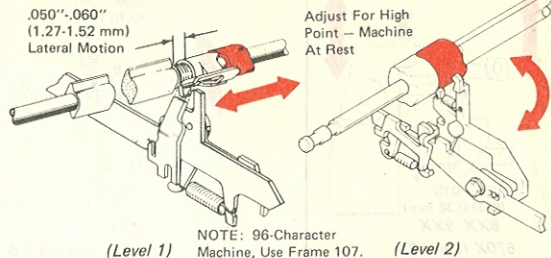

146 Spacebar Lockout (17-353)

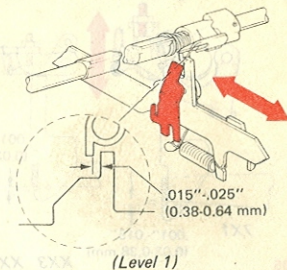

147 Interposer Guide (25-238)

148 Spacebar Interlock Bracket (25-226)

149 Interlock Stop (25-232)

150 Space-To-Print Interlock (17-404)

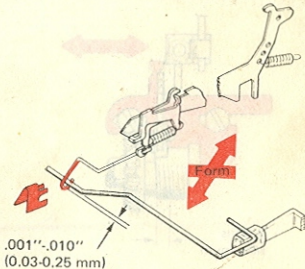
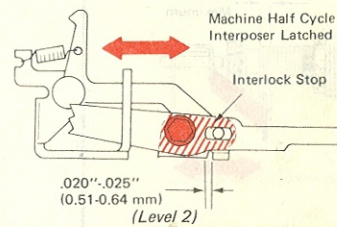
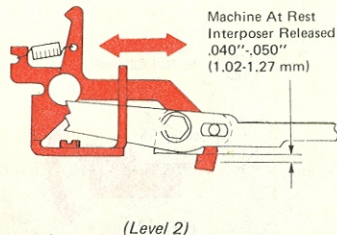
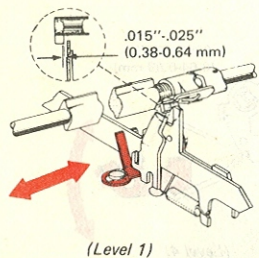

151 CR Latch Actuating Arm (03-203)

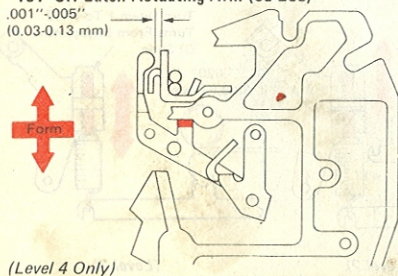

152 Pawl Clearance (03-420) (03-612) (03-203)

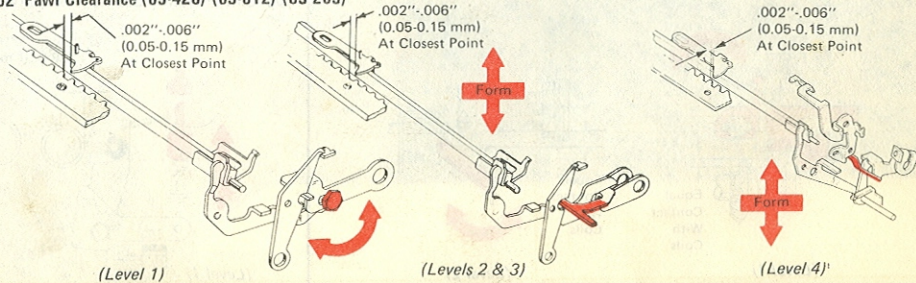



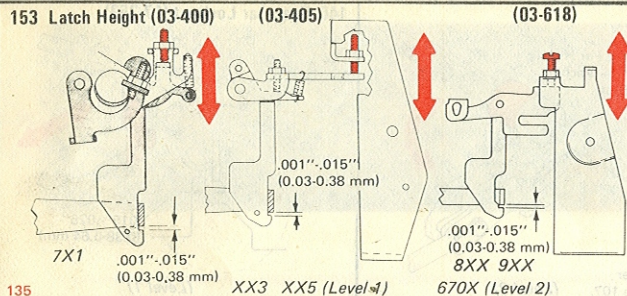

135

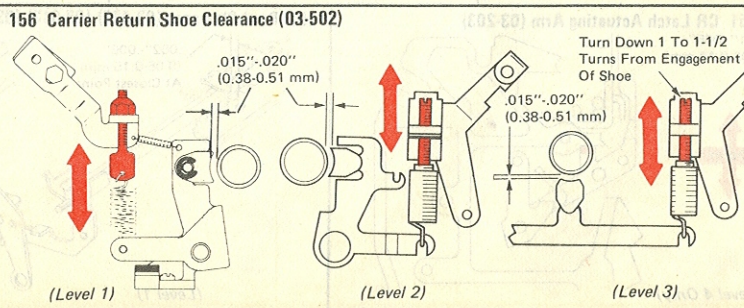
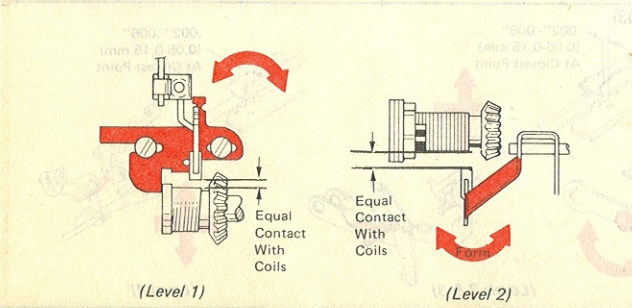
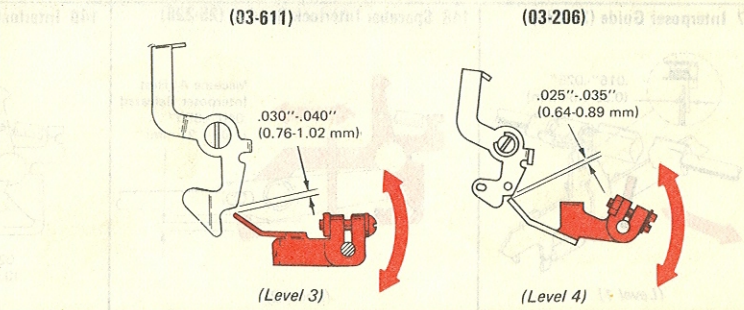
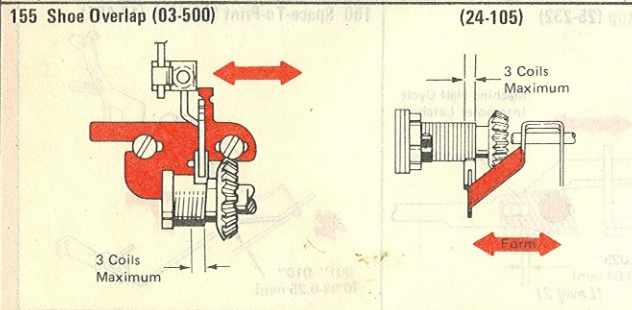
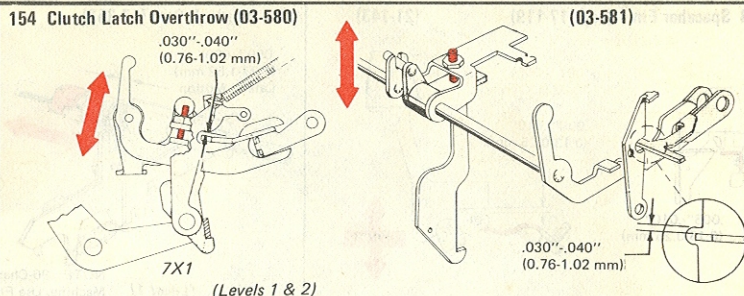

**157 Overbank (09-6)**

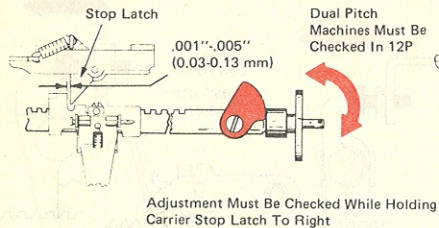

Dual Pitch  
Machines Must Be  
Checked In 12P

Adjustment Must Be Checked While Holding  
Carrier Stop Latch To Right

344 (Level 1)

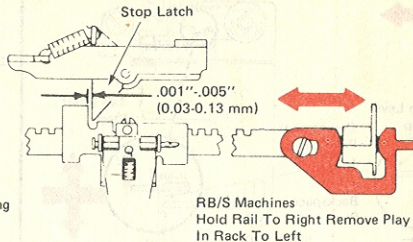

RB/S Machines  
Hold Rail To Right Remove Play  
In Rack To Left

(Level 2)

**158 Overbank Motion (09-21)**

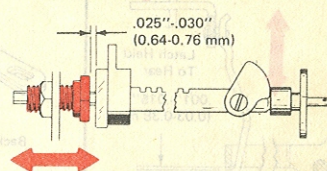

(Level 1)

**159 Clutch Unlatching (03-557)**

Margin Rack Hold  
To Left

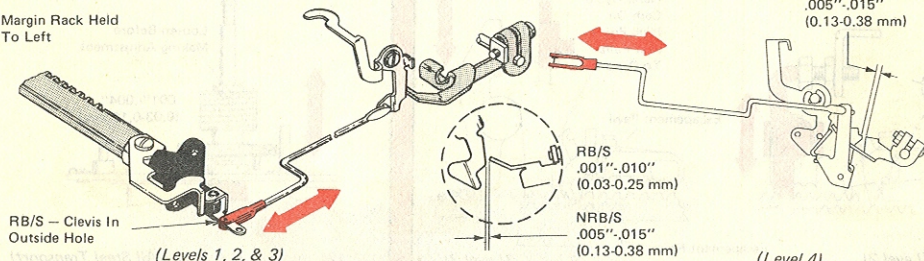

(03-202)

(Level 4)

**160 Torque Bar Latch (03-207)**

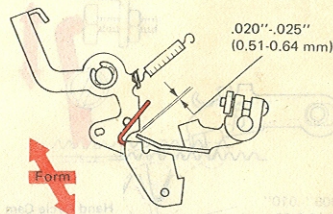

(Level 4 Only)

**161 Torque Limiter (25-5)**

1 To 1-1/2 Lbs.  
(454-680.8 g)  
Pull

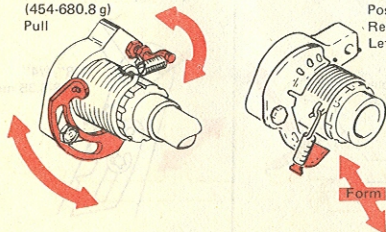

(Level 1)

(Level 2)

**162 CR Printer Interlock (03-625)**

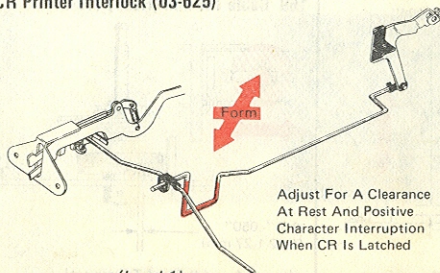

(Level 1)

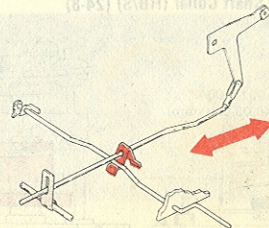

(Level 2)

163 Backspace Latch Height (NRB/S) (01-309)

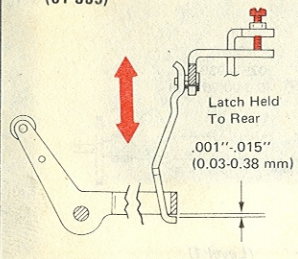

164 Tab Lever Stop (NRB/S) (01-314)

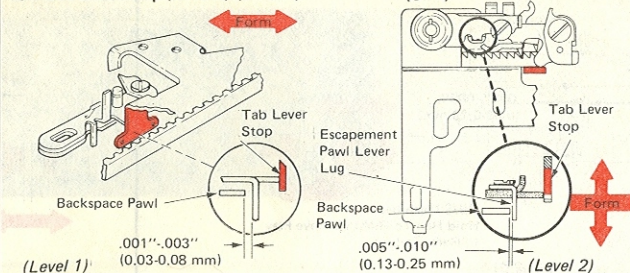

165 Backspace Rack (NRB/S) (01-307)

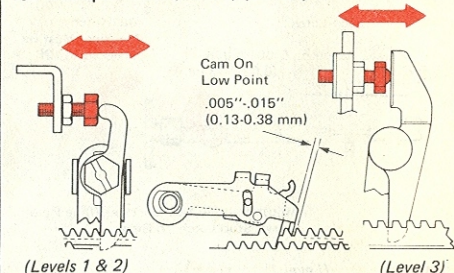

166 Backspace Rack Motion (NRB/S) (01-329)

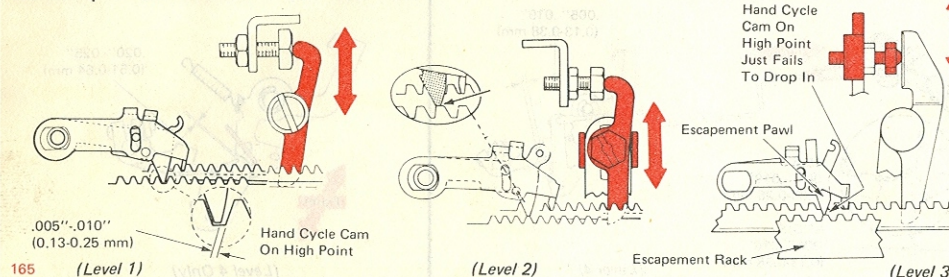

167 Mainspring Hub (RB/S) (19-13)

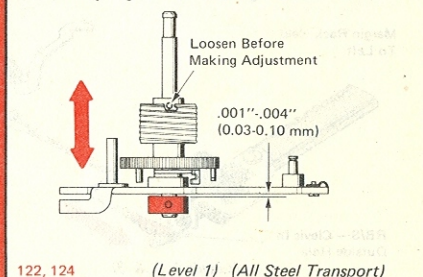

168 Escapement Shaft Collar (RB/S) (24-8)

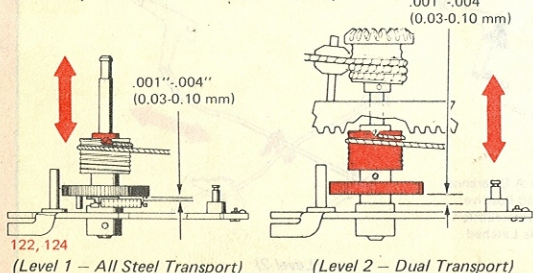

169 Cable Tension (RB/S) (19-23)

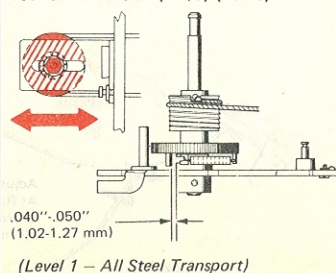

170 Rotary Backspace (25-210) Interposer Spring



171 Pitch Cam Cable Cover (24-37)

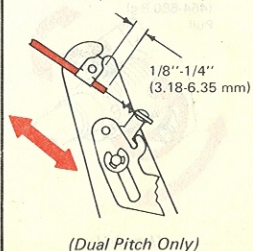

**172 Pitch Cam (24-37)**

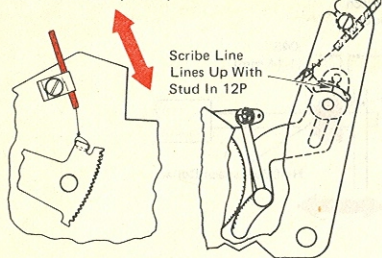

(Dual Pitch Only)

**173 Backspace Motion (24-26)**

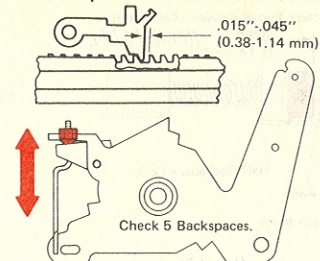

171, 172 (Level 1)

NOTE: Dual Pitch Machines Check In 10 Pitch.

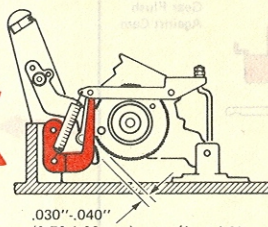

(Level 2)

Reliable Backspace With Slight Finger Pressure On Carrier

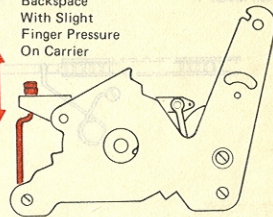

**174 Backspace Latch Height (24-15)**

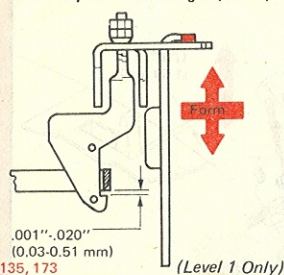

**175 Index Interlock Link (24-16)**

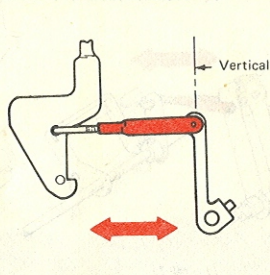

**176 Index Interlock Shaft (24-20)**

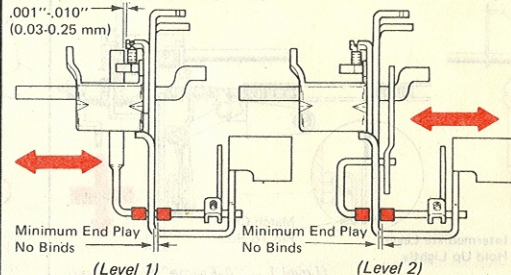

**(24-18)**

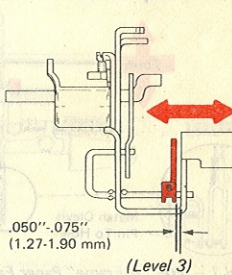

**177 Index Interlock Paddle (24-20)**

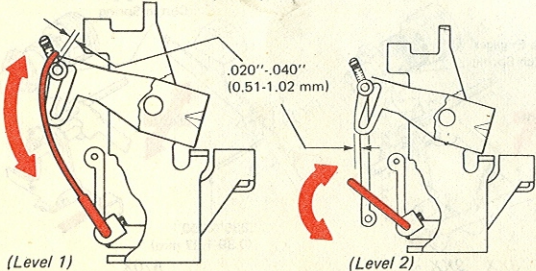

**178 Index Transfer Bellcrank Stop Lug (24-9)**

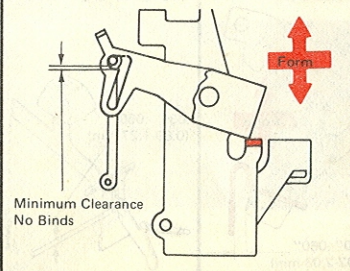

**179 Lower Half Backspace Link (07-7)**

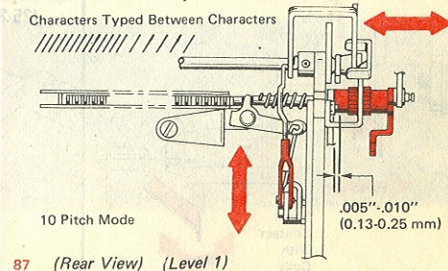

**180 Switch Pitch Gear (07-23)**

12 Pitch Mode

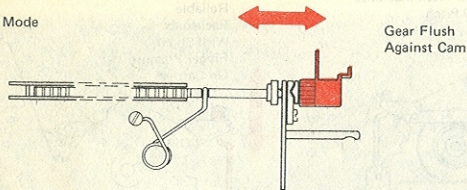

(Levels 2 & 3)

**181 Half Backspace Collar (07-105)**

Characters Typed Between Characters

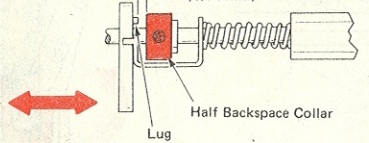
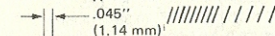

12 Pitch Mode

(Level 2)

12 Pitch Mode

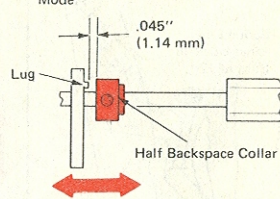

(Level 3)

**182 Half Backspace Rest Position (07-37)**

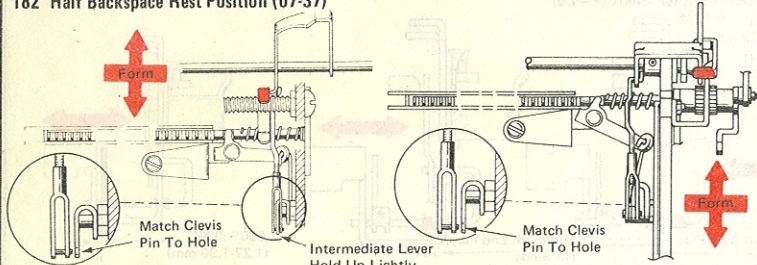

(Level 1 - Pre-"A-Frame" Paper Feed)

(Level 1 - "A-Frame" Paper Feed)

**183 Half Backspace Lever (07-32)**

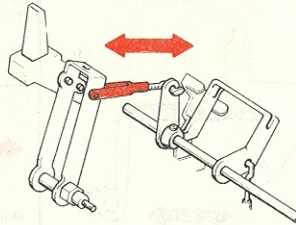

(Level 1)

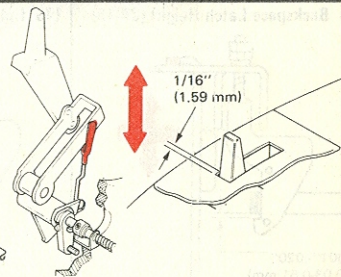

(Levels 2 & 3)

**184 Shoe Overlap (24-105)**

3 Coils Maximum

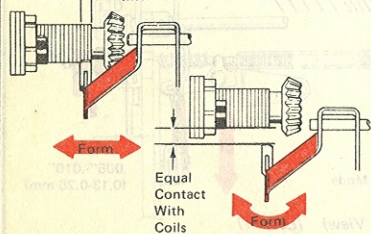

**185 Keylever Pawl Guide (25-238)**

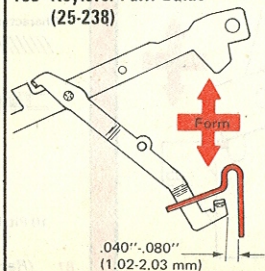

**186 Shoe Clearance (24-111)**

Shoe Engages Clutch Spring

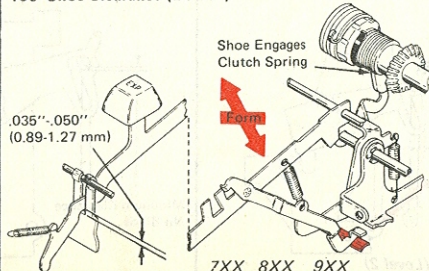

7XX 8XX 9XX

Shoe Engages Clutch Spring

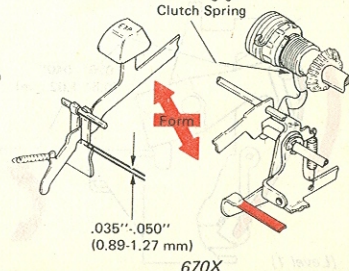

670X

187 Keylever Pawl (24-102)

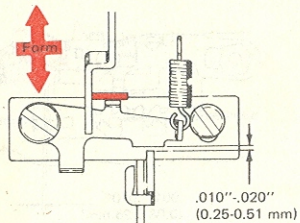

(NRB/S)

188 Keylever Pawl (24-205)

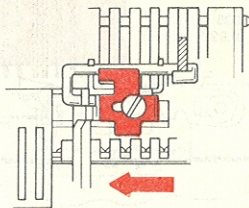

670X

189 Express Backspace Latch (24-102)

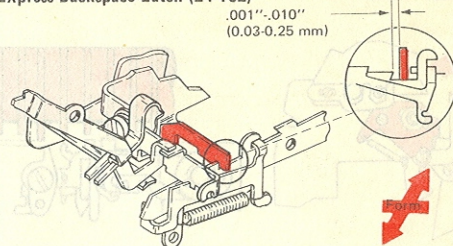

(NRB/S)

190 Tab Rack Radially (18-35) (19-31)

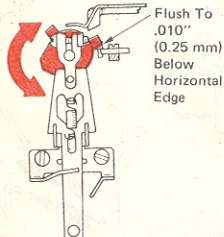

Check 95 First.

(NRB/S Pre-Snap In Tab)

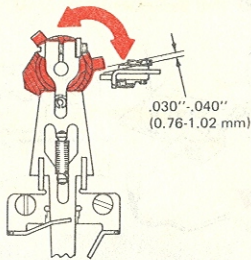

(NRB/S Snap In Tab And RB/S)

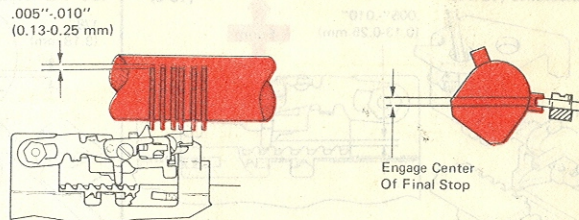

Engage Center  
Of Final Stop

191 Tab Lever Stop (18-153)

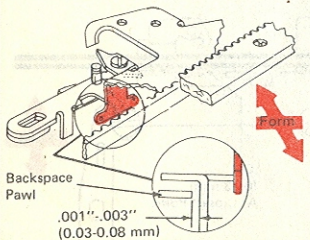

Check 94 First.

(NRB/S)

(19-69)

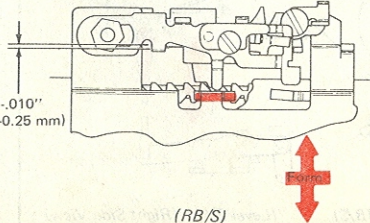

(RB/S)

192 Tab Lever Pawl (18-152)

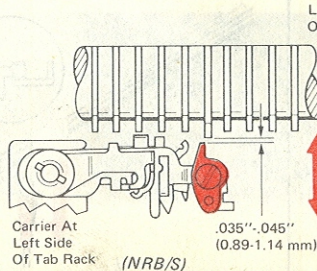

Carrier At  
Left Side  
Of Tab Rack

(NRB/S)

Carrier At  
Left Side  
Of Tab Rack (19-68)

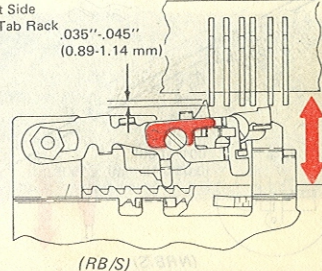

(RB/S)

193 Tab Rack Parallel

(18-30)

(19-29)

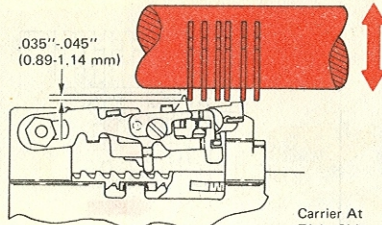
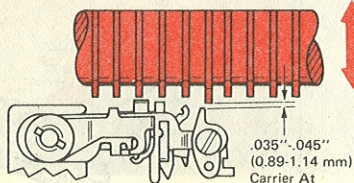
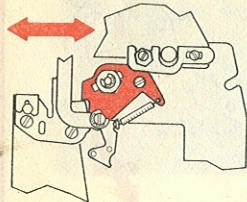

(Right Side View)

(NRB/S)

(RB/S)

Carrier At  
Right Side  
Of Tab Rack

194 Tab Latch Bite (19-9)

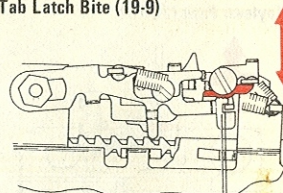

.001"-.010"  
(0.08-0.25 mm)

(RB/S)

195 Pawl Clearance (18-81)

(19-9)

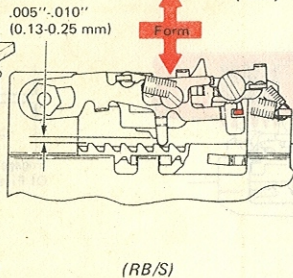
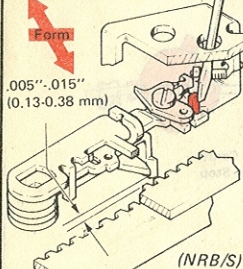

(NRB/S)

(RB/S)

196 Tab Keylever Link (18-58)

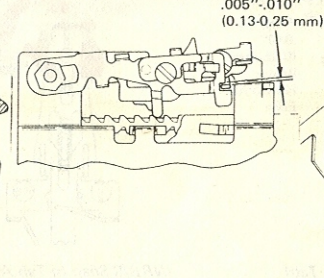
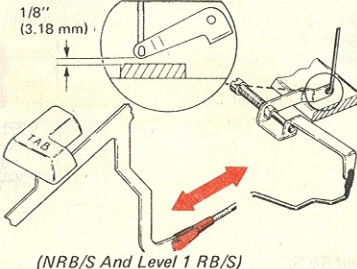

(19-78)

(Level 2 - RB/S)

197 Tab Torque Bar Link (18-19)

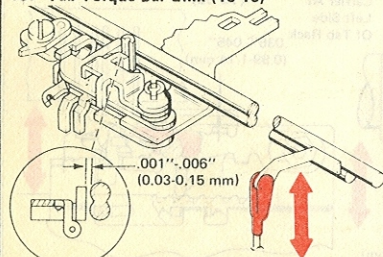

(NRB/S)

198 Tab Torque Bar Link (19-47)

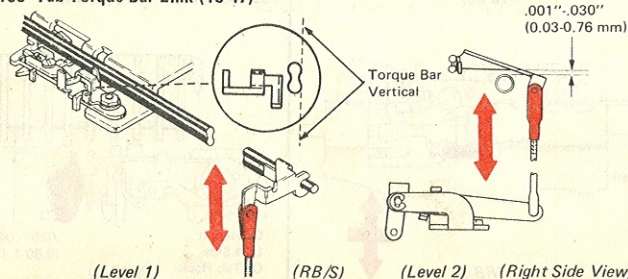

(Level 1)

(RB/S)

(Level 2)

(Right Side View)

199 Tab Torque Bar Backup Lug (07-001)

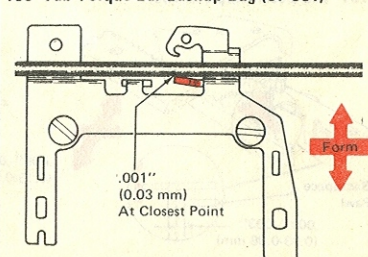

196

(RB/S)

200 Tab Trigger (19-71)

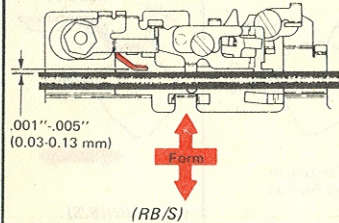

201 Overthrow Stop (18-91)

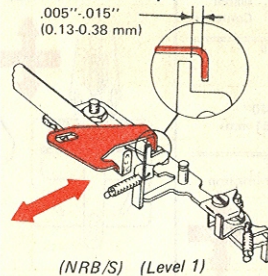

202 Tab Lever Overthrow (19-41)

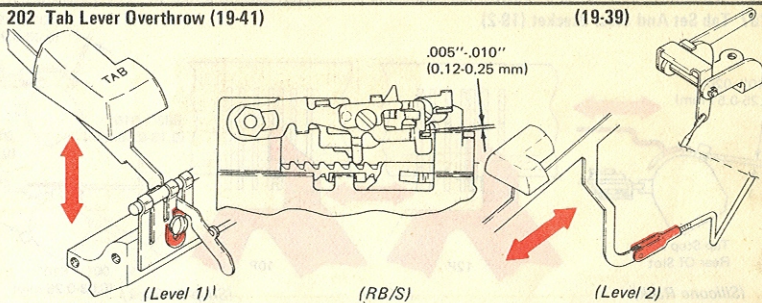

203 Tab Rack Left To Right (18-07)

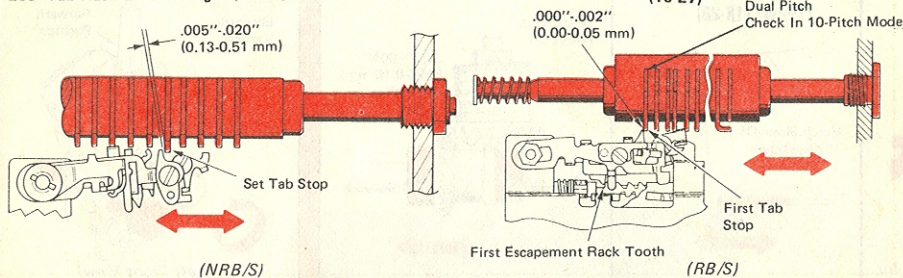

204 Tab Interlock (18-81) (19-9)

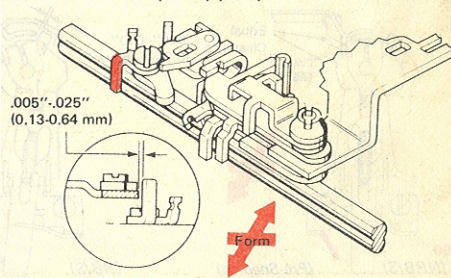

205 Carrier Return Tab Interlock (03-575)

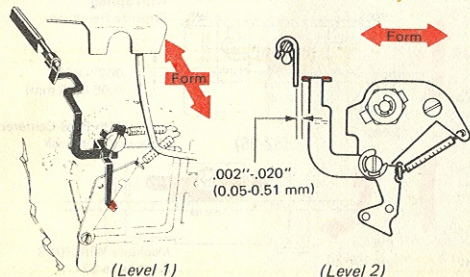

206 Tab Rack Vertical (18-30) (19-29)

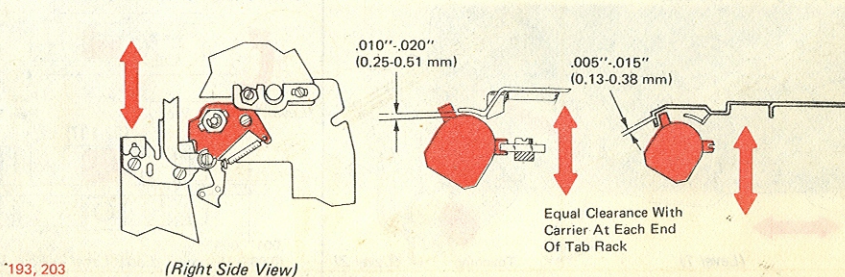



**207 Tab Set And Clear Bracket (19-2)**

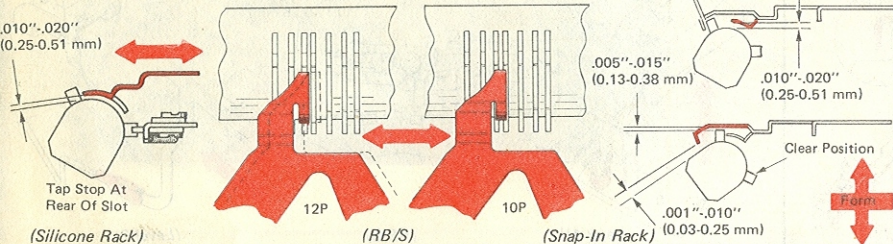

**208 Tab Set (18-16) (19-55)**

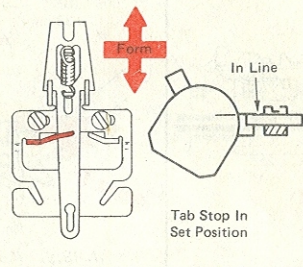

**209 Tab Clear Bracket (18-132)**

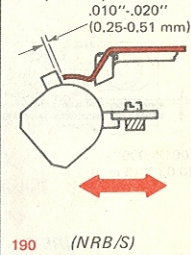

**210 Tab Clear (18-16) (19-55)**

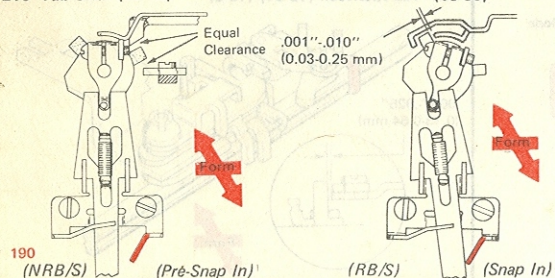

**211 Tab Set And Clear Link (19-54) (18-20)**

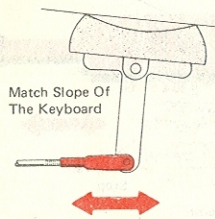

**212 Tab Pinion Backlash (25-20)**

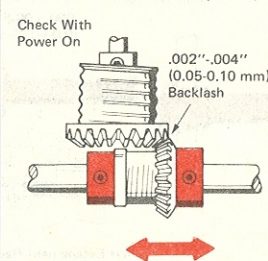

**213 Copy Control Lever (22-254)**

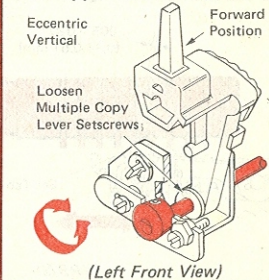

**214 Platen Adjusting Plates (22-252)**

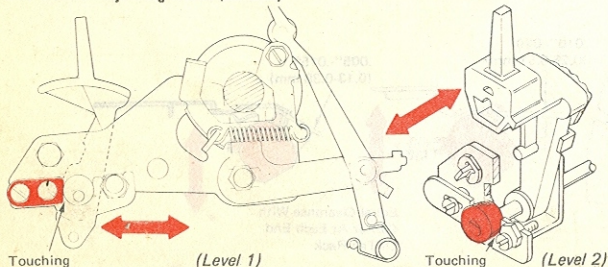

**215 Carrier Shoe (02-119) (02-112)**

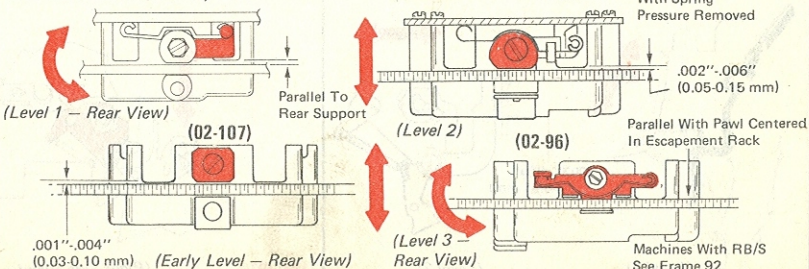

216 Carrier Support (02-8)

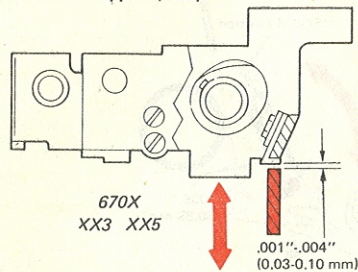

217 Anvil (02-008)

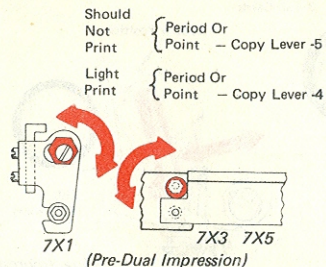

218 Buffers (02-101)

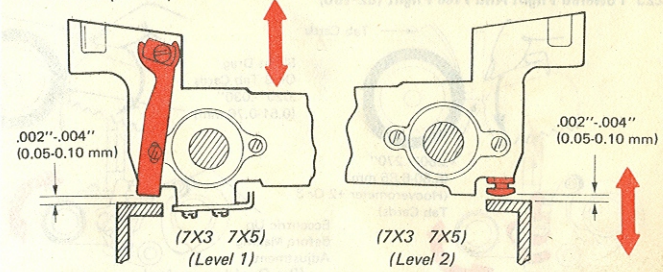

219 Platen Latches (22-293)

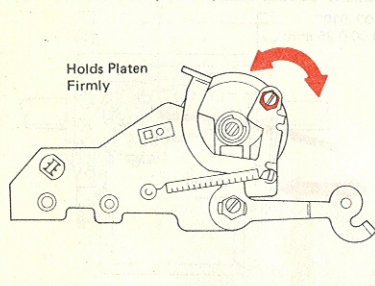

220 Platen Front To Rear (22-253)

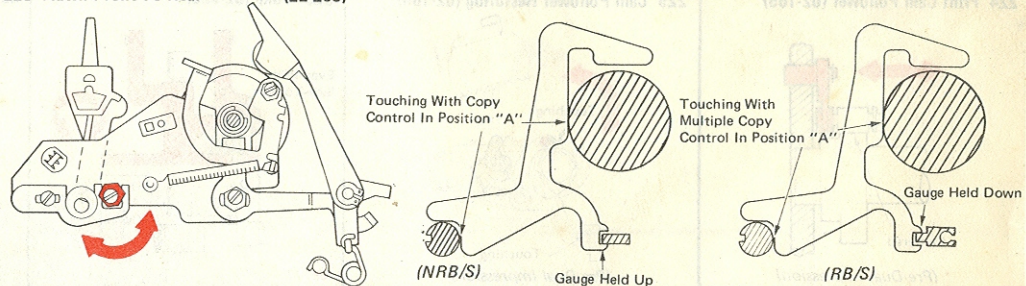

221 Platen Height (22-291)

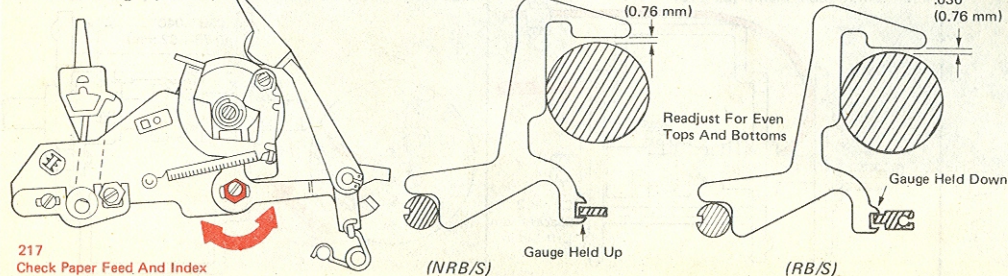

222 Print Cam Follower Stop Screw (02-205)

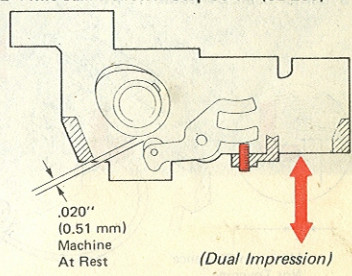

217  
Check Paper Feed And Index

**223 Powered Flight And Free Flight (02-160)**

Tab Cards

Slight Drag On 3 Tab Cards  
.020"-.030"  
(0.51-0.76 mm)

3 Tab Cards

Stick 4 Position

Stick 4 Position

.260"-.270"  
(6.60-6.85 mm)  
(Hooverometer +2 Or 3 Tab Cards)

Eccentric Up Before Making Adjustment  
(Pre-Dual Impression)

.250"  
(6.35 mm)

.035"  
(0.89 mm)

(Dual Impression)

**224 Print Cam Follower (02-165)**

Centered

(Pre Dual Impression)

**225 Cam Follower Restoring (02-165)**

Touching

Touching

(Pre-Dual Impression)

**226 Yoke (02-520)**

Even Print Side-To-Side

69, 77

**227 Velocity Control Cable Clamp (02-216)**

.000-.010"  
(0.00-0.25 mm)

Loosen Screw

**228 Carrier Cable Deflector (19-74)**

Minimum Clearance Not Touching

**229 Center Cable Clamp (02-216)**

Just Touches

Carrier 2 Spaces From Left Limit

**230 Velocity Control Keyboard Cable Clamp (02-216)**

.030"-.040"  
(0.76-1.02 mm)

**231 Low Velocity Latch Link (21-411)**

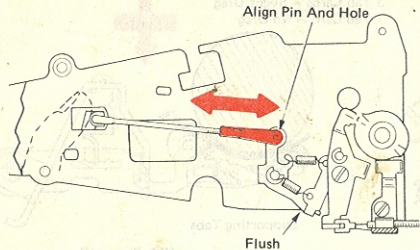

**232 Low Velocity Cam (21-426)**

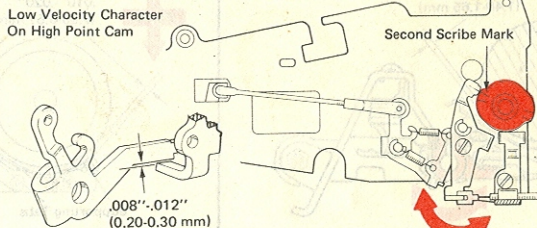

**233 Low Velocity Cam Follower Stop (21-415)**

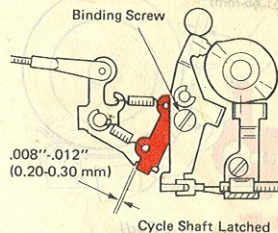

**234 Paper Feed Support (22-208)**

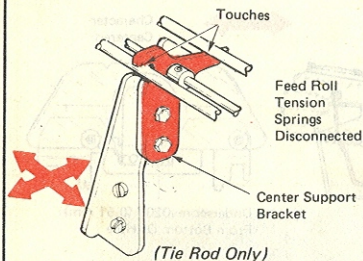

**235 Platen Latches (22-293)**

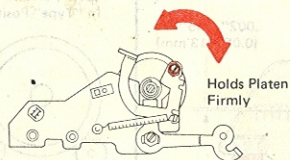

**236 Feed Roll Tension (22-286)**

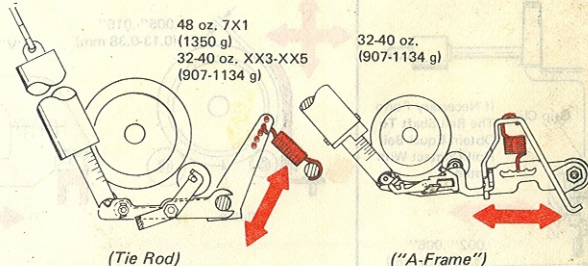

**237 Feed Roll End Play (22-96)**

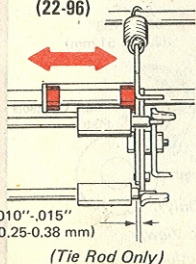

**238 Feed Rolls (22-286)**

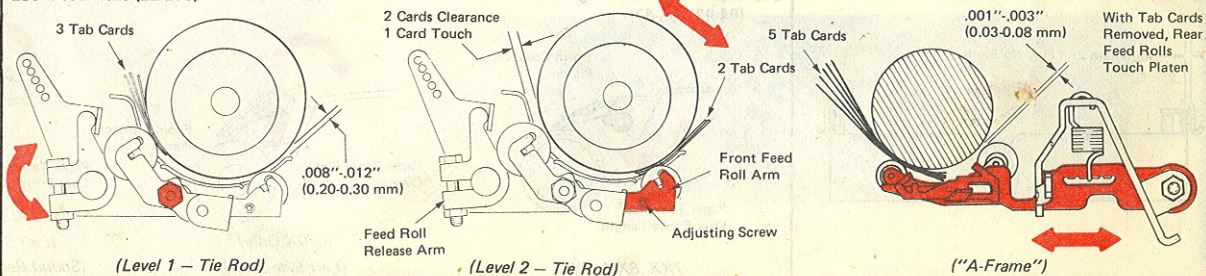

239 Paper Release (22-93)

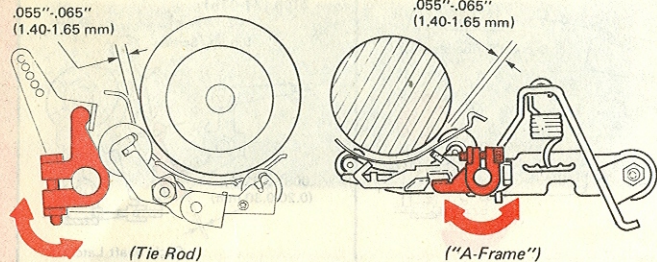

240 Deflector (22-134)

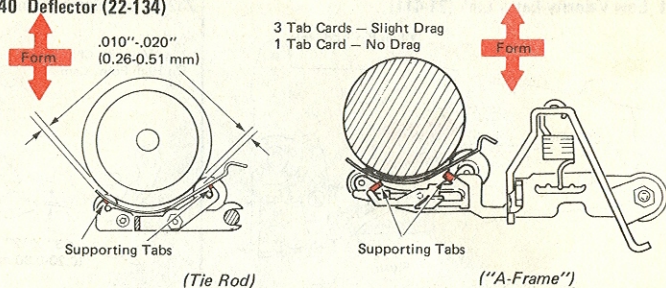

241 Paper Bail (22-1)

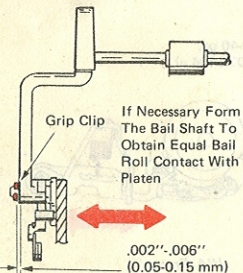

242 Cardholder (22-216)

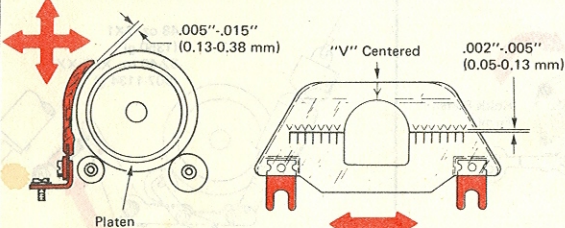

243 Removable Print Shield (22-226)

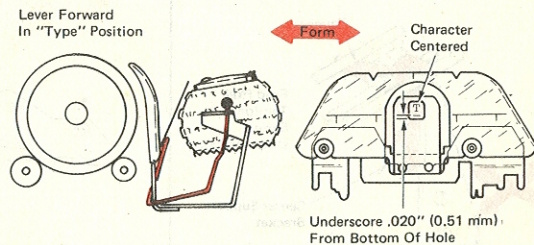

244 Paper Table Arm (04-90) (05-56)

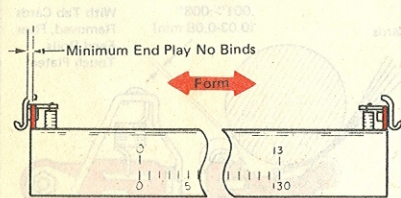

245 Paper Table Mounting Bracket (04-92) (05-47)

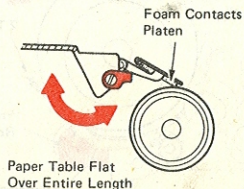

7XX 8XX 9XX

(05-141)

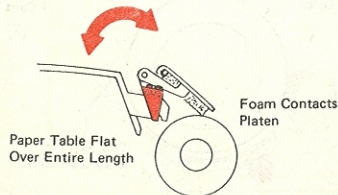

(670X Only)  
(Left Side View)

(30-141, 166)

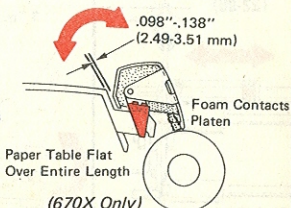

(670X Only)  
(Left Side View)  
(Sound Reduction Only)

## 246 Switch Bracket (24-9)

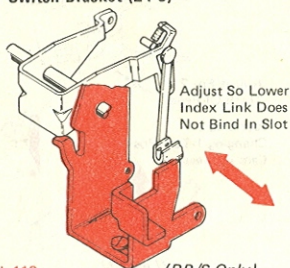

Check 119

(RB/S Only)

## 247 Multiplying Lever Stop (20-412)

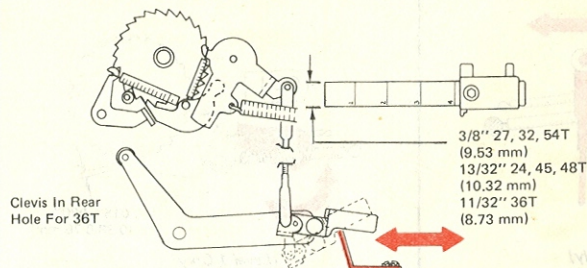
Clevis In Rear  
Hole For 36T

## 248 Index Transfer Bellcrank Stop Lug (24-9)

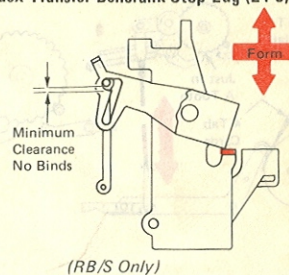

## 249 Ratchet Alignment (12-20)

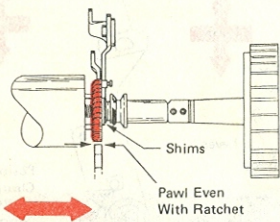

## 250 Index Selector Cam (20-318)

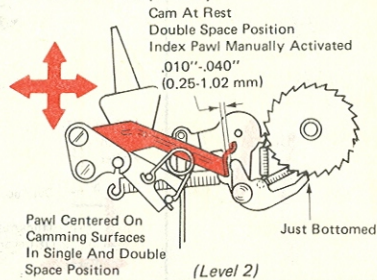

## 251 Index Selector Cam 54T (20-322)

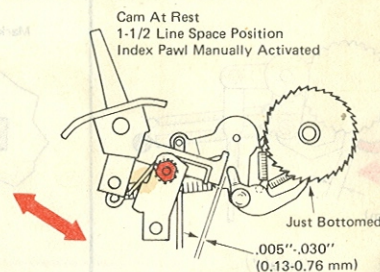

## 252 Index Link (20-403)

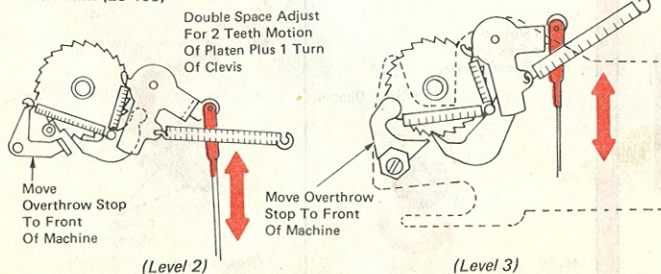

## 253 Overthrow Stop (20-452)

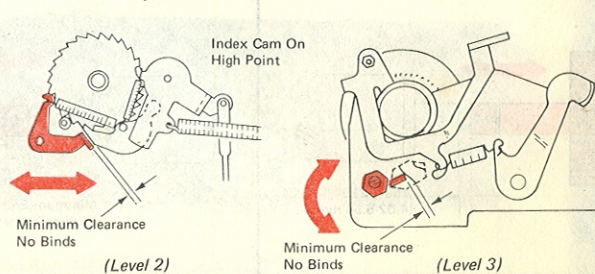

254 Index Link And Stud (20-401)

Adjust For 1T Motion Of Platen

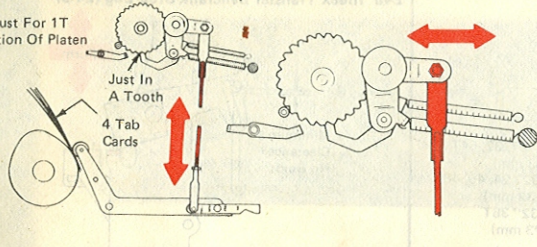

(Level 1 Only)

255 Upper Index Pawl Stop (20-437)

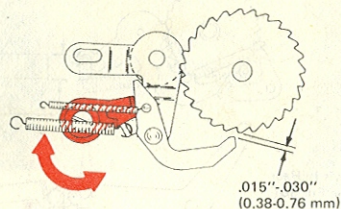

(Level 1 Only)

256 Multiplying Control Lever (20-314)

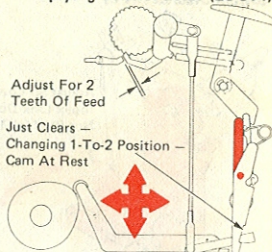

(Level 1)

257 Platen Overthrow Stop (20-452)

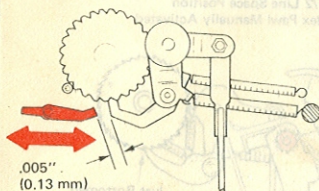

(Level 1)

258 Index Selector Lever (20-301)

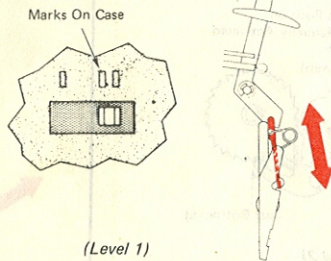

(Level 1)

259 Line Position Reset Lever (12-32)

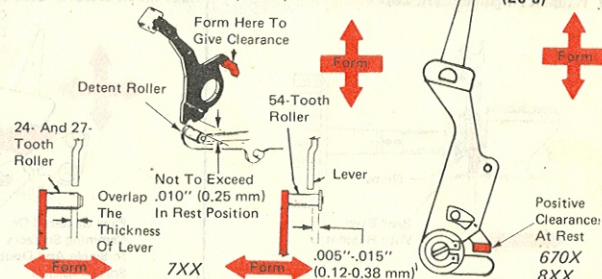

(20-5)

Positive Clearance: At Rest  
670X  
8XX

260 Left Platen Knob (12-55)

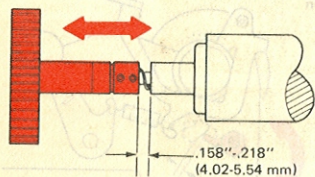

261 Right Platen Knob (12-55)

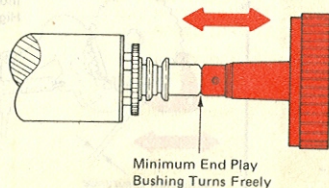

262 Ribbon Lift Cam (14-117)

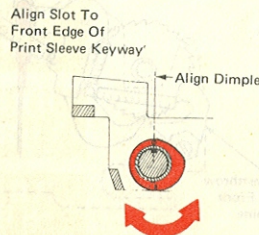

44, 54

263 Feed Cam Follower Bracket (14-158)

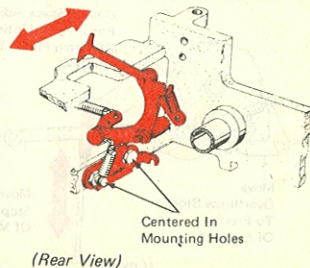

(Rear View)

264 Ribbon Plate (14-44)

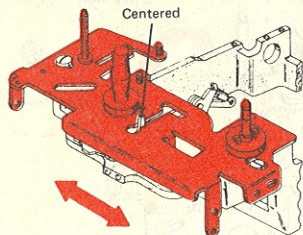

265 Ribbon Feed Cam Follower Stud (14-136)

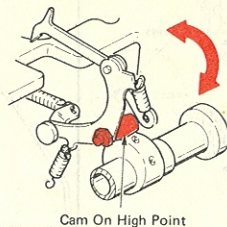

1/16 Turn =  
1 Feed Operation

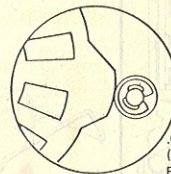
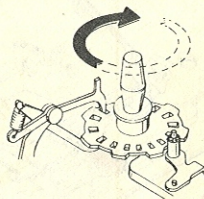

.005"-.015"  
(0.13-0.38 mm)  
Beyond Detent Position  
Cam On High Point

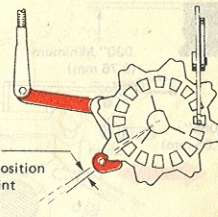

(Level 1 - Top View)

(Level 2 - Top View)

266 Feed And Lift Wheel Detent Spring (14-48)

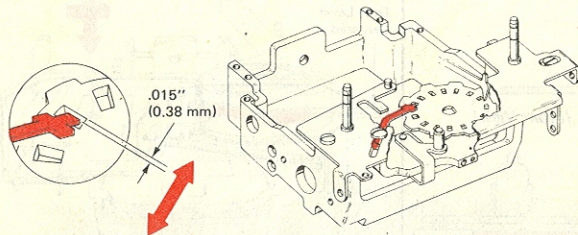

(Level 1 Only)

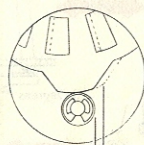

.015"  
(0.38 mm)

267 Brake Actuating Lever (14-30)

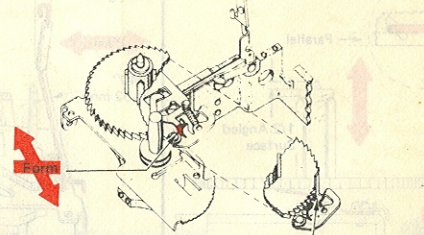

(Level 1 Only)

268 Ribbon Lift Guide Plate (14-207)

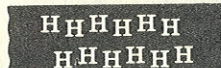
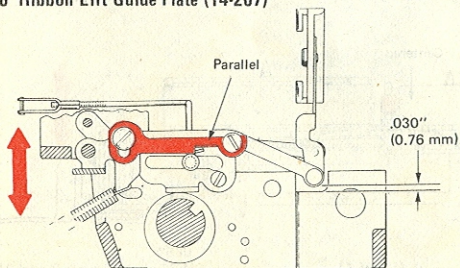

A LIFT GUIDE  
PLATE PARALLEL  
TO SLOT IN CAM  
FOLLOWER



B LIFT GUIDE  
PLATE OUT OF  
PARALLEL TOO  
HIGH AT THE  
REAR



C LIFT GUIDE  
PLATE OUT OF  
PARALLEL TOO  
HIGH AT THE  
FRONT

Approximately .030"  
(0.76 mm)

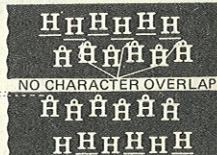

D LIFT GUIDE  
PLATE PARALLEL  
TO SLOT IN CAM  
FOLLOWER

E LIFT GUIDE  
PLATE PARALLEL  
TO SLOT IN CAM  
FOLLOWER

Approximately .050"  
(1.27 mm)



269 Ribbon Lift Control Link (14-128)

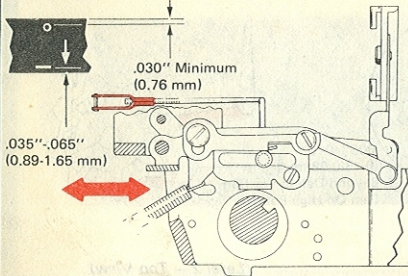

270 Load Lever Link (14-147)

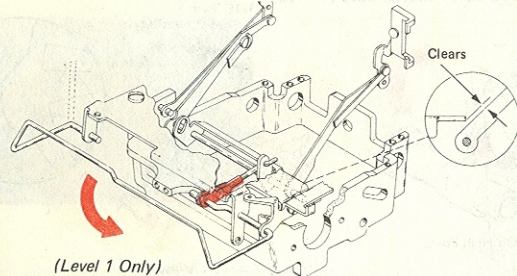

(Level 1 Only)

271 Pressure Roller Release Arm (14-116)

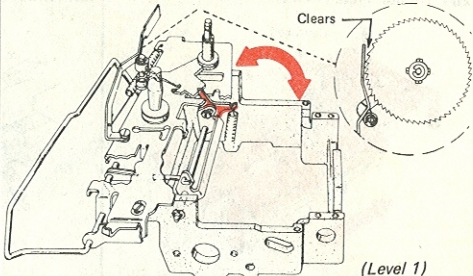

(Level 1)

272 Supply Spool Drag Spring (14-30)

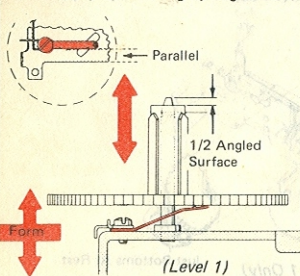

(Level 1)

273 Shock Wire (14-26)

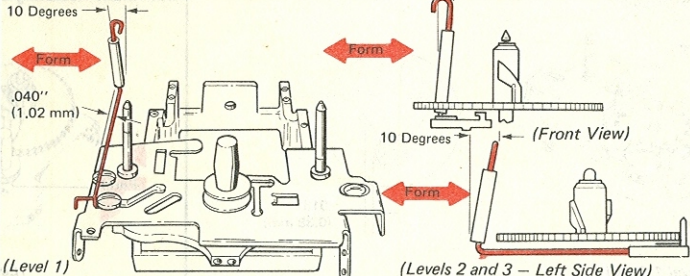

(Level 1)

(Levels 2 and 3 - Left Side View)

274 Drag Lever (14-80)

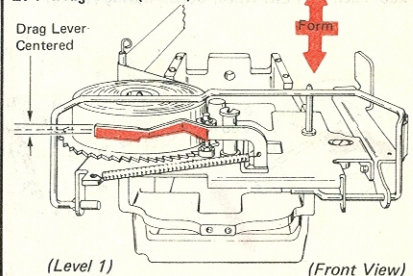

(Level 1)

(Front View)

275 Tracking Post Vertical (14-82)

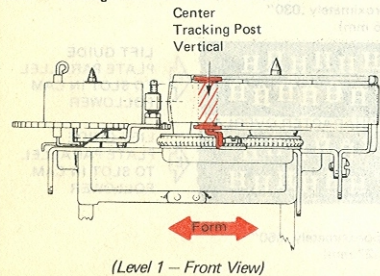

(Level 1 - Front View)

276 Tracking Post (14-82)

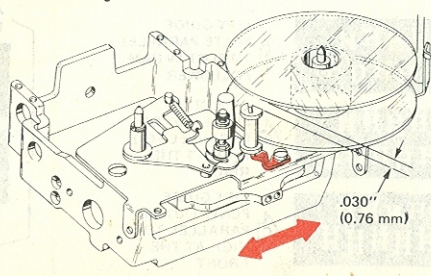

277 Pressure Roller (14-12)

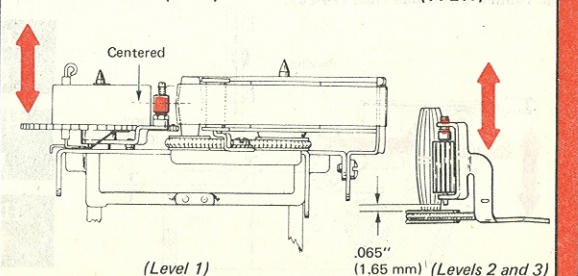

(Level 1)

$.065''$  (1.65 mm) (Levels 2 and 3)

**278 Ribbon Lift Cam (13-58)**

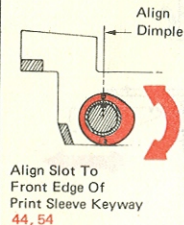

**279 Centering Spring (13-38)**

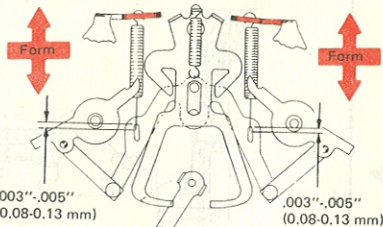

(Level 1 Only - Top View)

**280 Ribbon Feed Plate (13-38)**

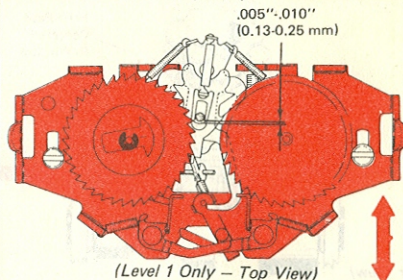

(Level 1 Only - Top View)

**281 Cartridge Guide Lugs (13-38)**

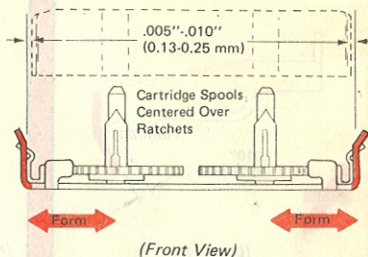

(Front View)

**282 Cartridge Retaining Springs (13-76)**

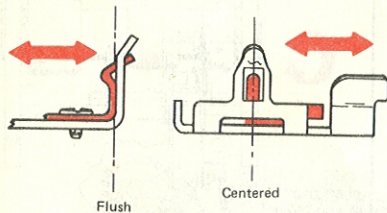

(Level 2)

**283 Ribbon Lift Lever (13-78)**

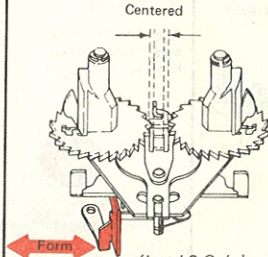

(Level 2 Only)

**284 Ribbon Lift Lever Rear Lug (13-78)**

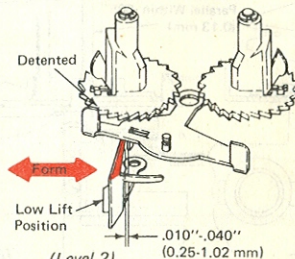

(Level 2)

**285 Ribbon Lift Lever Front Lug (13-78)**

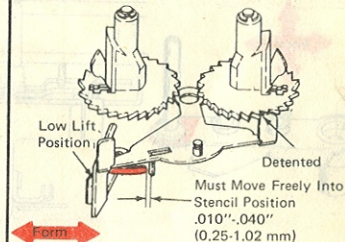

(Level 2)

**286 Ratchet Detent Lugs (13-74)**

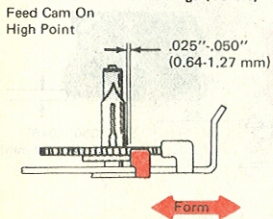

**287 Ratchet Detent Lug (13-74)**

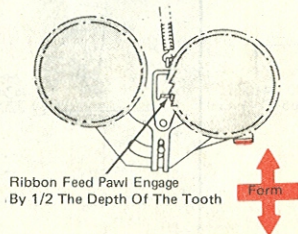

**288 Ribbon Lift Guide Plate (13-37)**

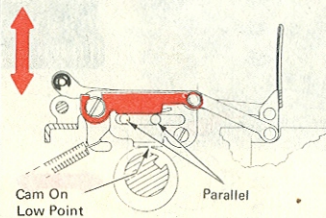

**289 Ribbon Lift Control Link (13-62)**

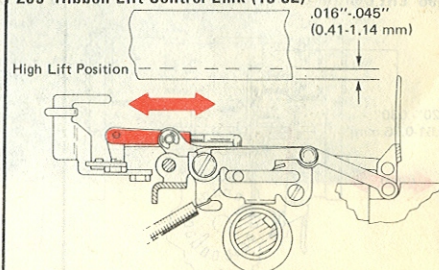

290 Stencil Lockout (13-65)

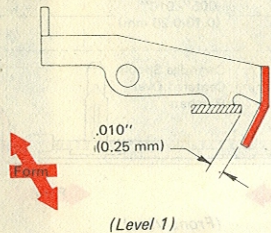

291 Feed Cam Follower Bracket (15-12)

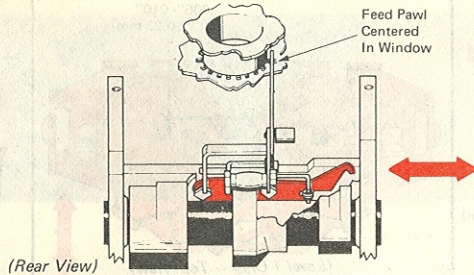

292 Lift Arm (15-6)

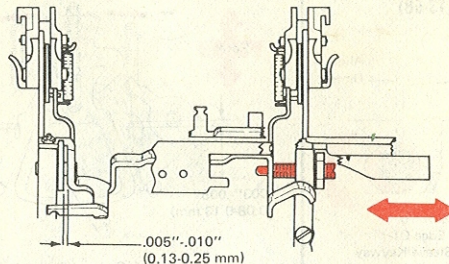

293 Spiked Driver Post (15-61)

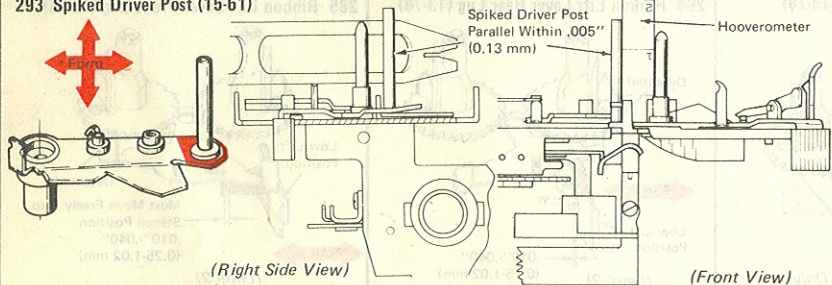

294 Ribbon Lift Cam (15-17)

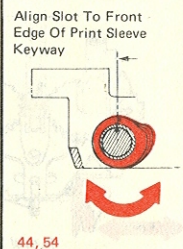

295 Feed Cam Follower Eccentric (15-8)

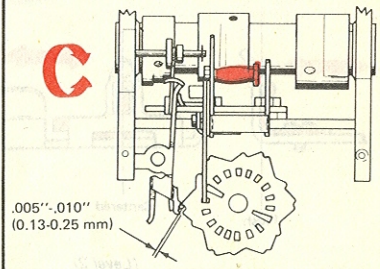

296 Lift Control Lever (15-76)

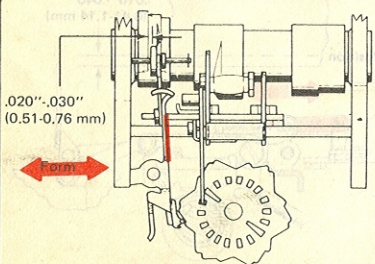

297 Spread Adjusting Plate (15-22)

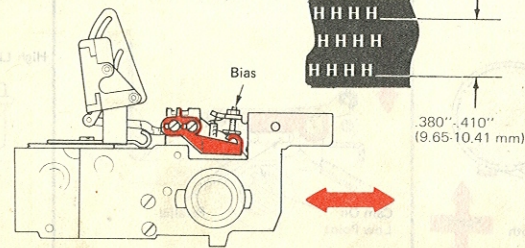

298 Lift Height (15-30)

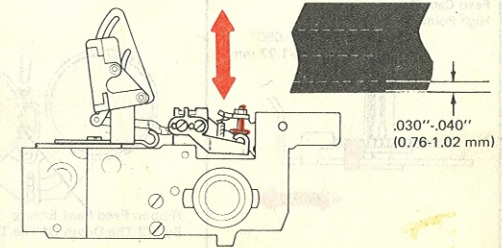

299 Lift Arm Lower Stop (15-2)

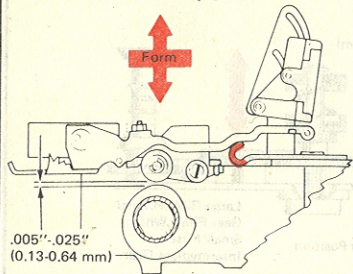

300 Shock Wire (15-83)

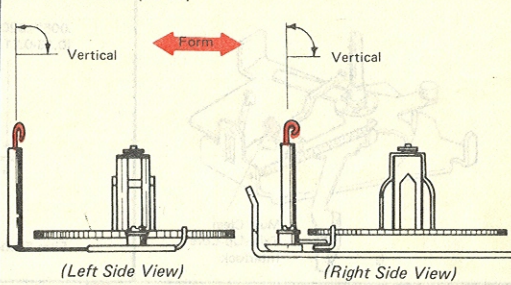

301 Stencil Adjustment (15-76)

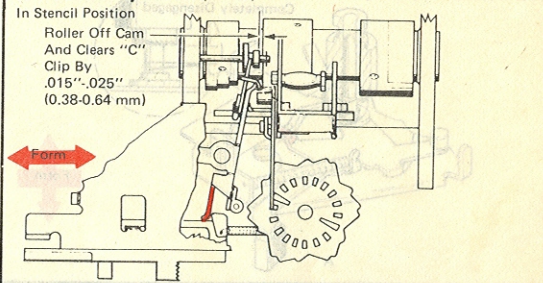

302 Swing Arm Lug (15-62)

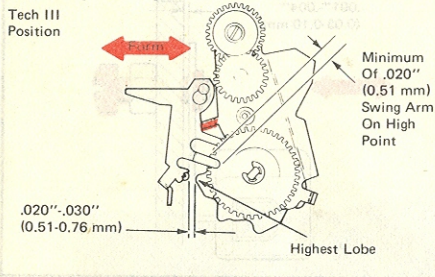

303 Shock Wire Disengage Lever (15-87)

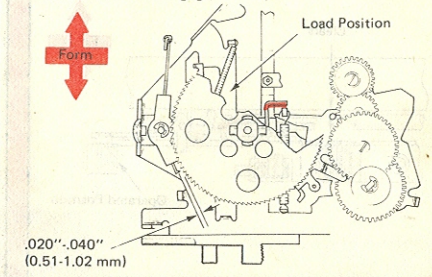

304 Shock Wire Disengage Lever (15-87)

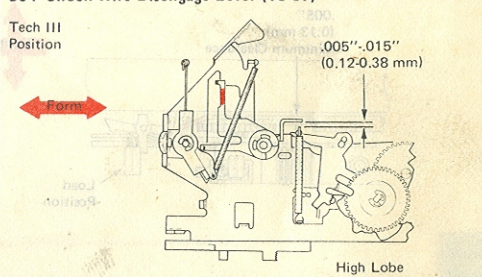

305 Cartridge Guides (15-86)

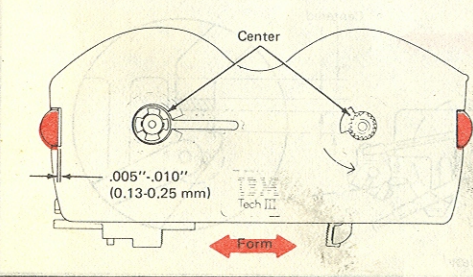

306 Cartridge Retaining Springs (15-59)

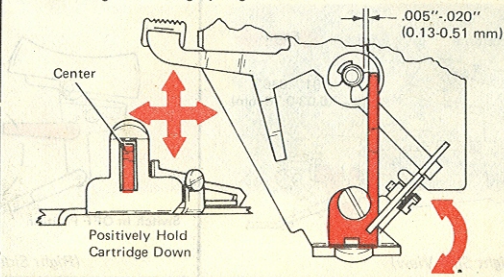

307 Take-Up Core Interlock (15-59)

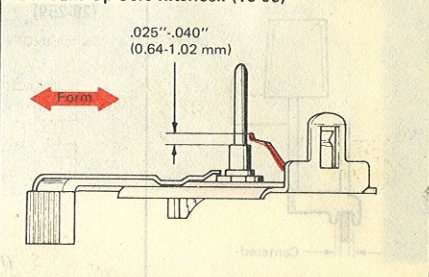

308 Load Lever (15-64)

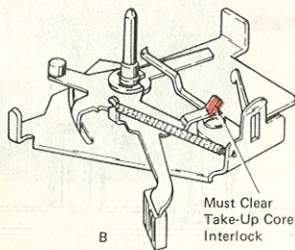
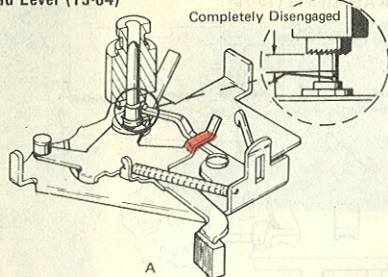

309 Mode Button Grip Clip Position (15-93)

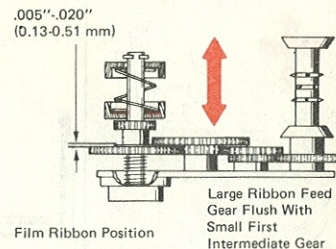

310 Load Lever Spring (15-85)

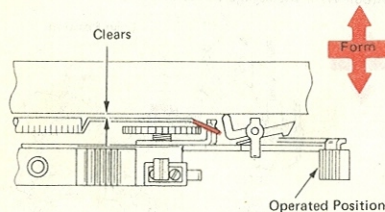
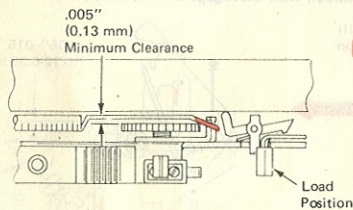

311 Correcting Keylever Side Play (26-95)

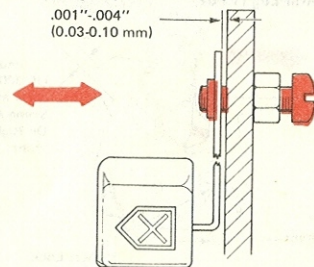

312 Backspace Keylever (01-101)

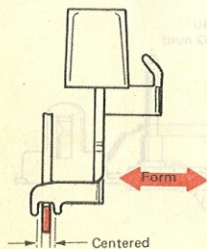

313 Correcting Keybutton Interlock Front To Rear (26-259)

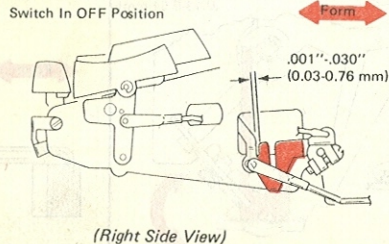

314 Lockout Bail Link (21-546)

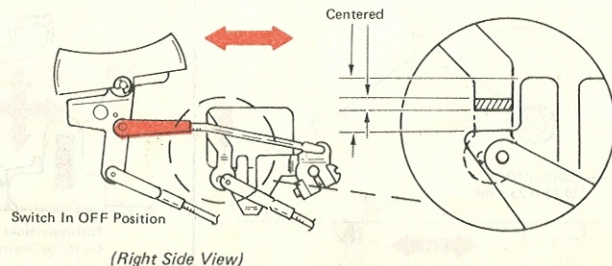

**315 Correcting Keypbutton Interlock And Lockout Bail (26-259)**

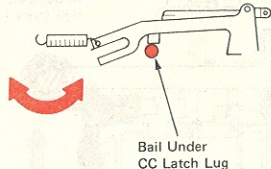
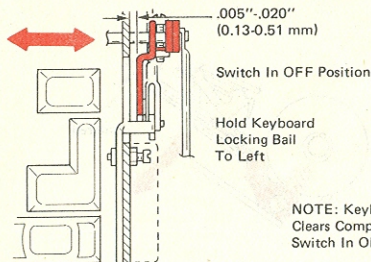

**316 Correcting Keylever Link (26-90)**

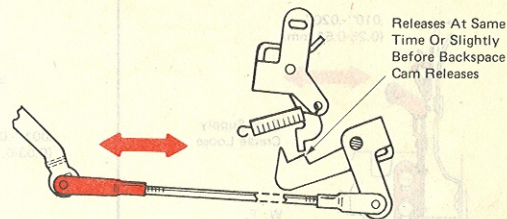

**317 Mode Actuating Bellcrank (26-80)**

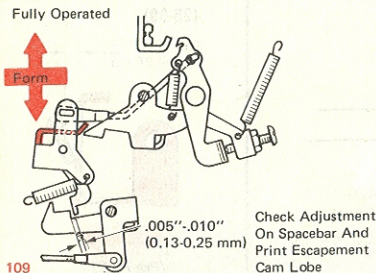

**318 Trigger Link (26-76)**

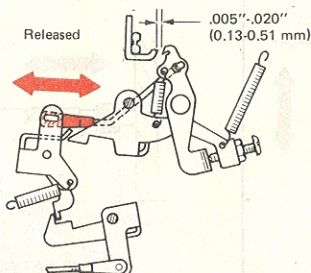

**319 Cable Guide Bracket (26-59)**

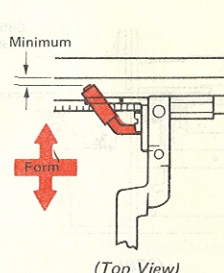

**320 Cable Guide Lug (26-71)**

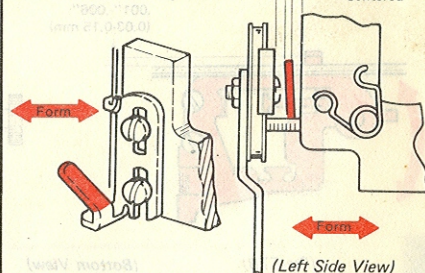

**321 Cardholder (26-41)**

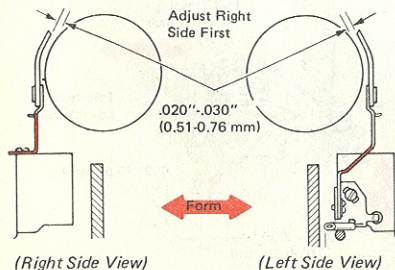

**322 Cardholder (26-41)**

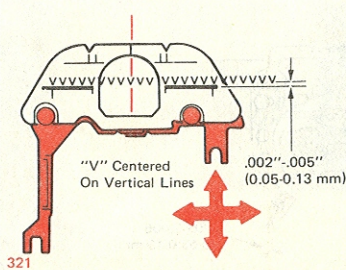

**323 Left-Hand Ribbon Lift Guide (26-72)**

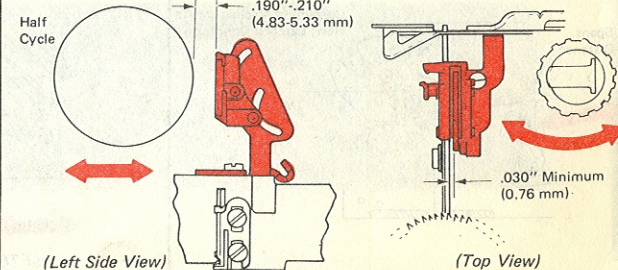

324 Tape Lift Assembly Front To Rear (26-71)

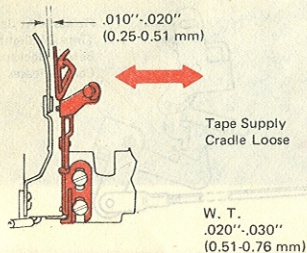

325 Tape Lift Assembly Vertical (26-71)

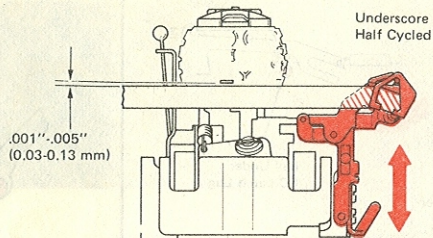

324

326 Tape Supply Cradle Fork (26-34)

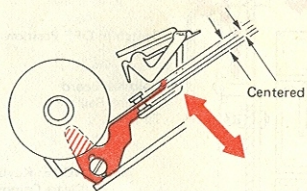

327 Torque Bar Back-Up Lug (26-55)

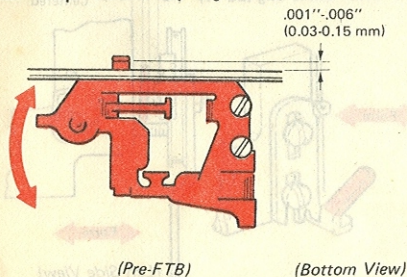

(26-132)

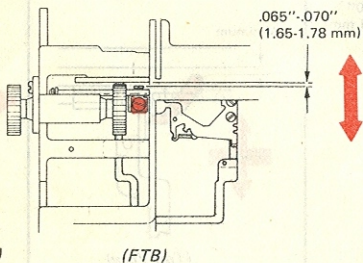

328 Correcting Torque Bar End Play (26-98)

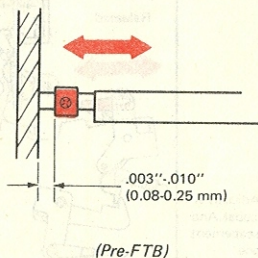

329 Torque Bar Stop Bracket (26-89)

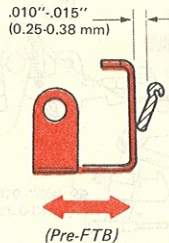

330 Torque Bar Link (Preliminary) (26-86)

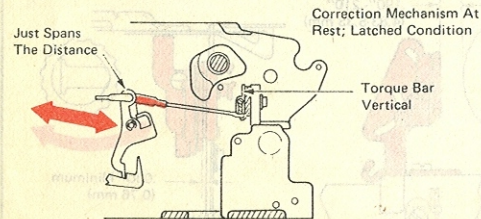

331 Lift Actuating Arm (26-62)

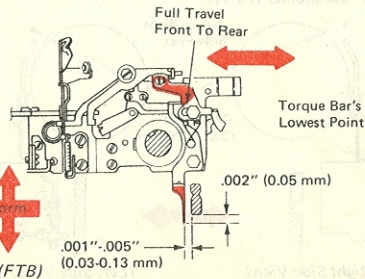
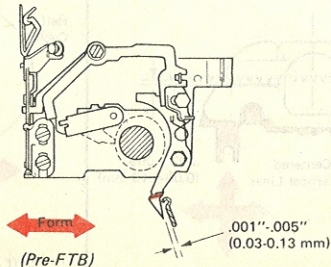

**332 Lift Arm Latch (26-66)**

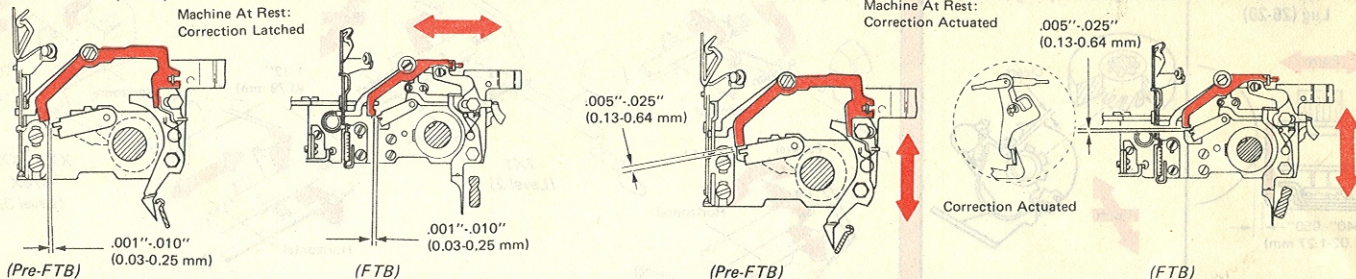

**333 Torque Bar Link (Final) (26-86)**

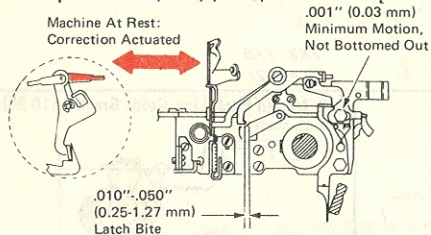

**334 Tape Feed Cam Follower Front Lug (26-53)**

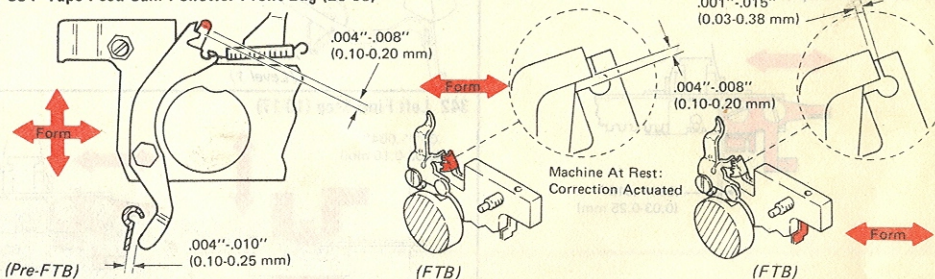

**335 Tape Feed Cam Follower Rear Lug (26-45)**

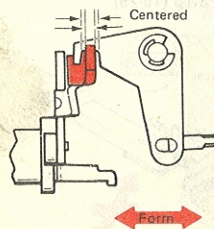

**336 Guide (26-13)**

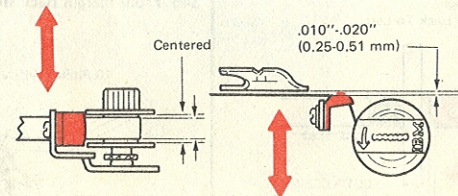

**337 Separator Wire (26-9)**

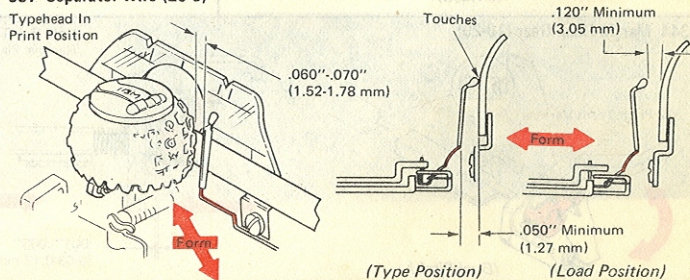



338 Paper Guide Lug (26-20)

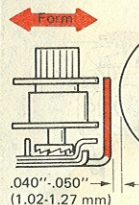

339 High Bias Spring (26-34)

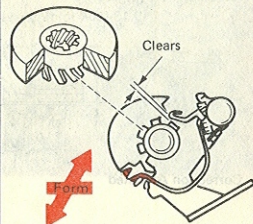

340 Margin Rack (09-19)

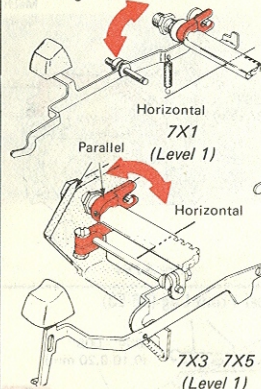

(09-61)

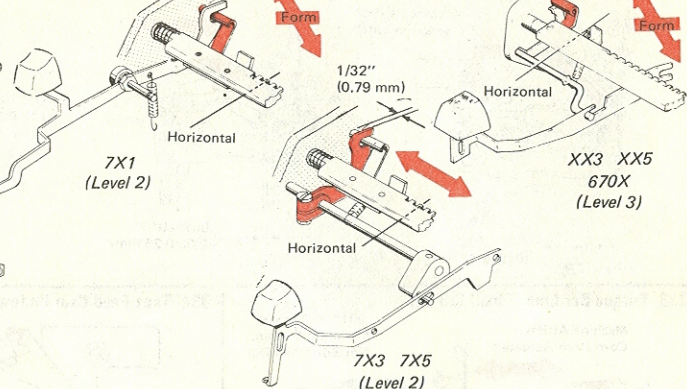

341 Left Final Stop (09-61)

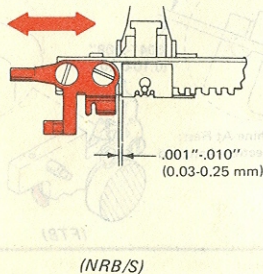

(NRB/S)

342 Left Final Stop (10-17)

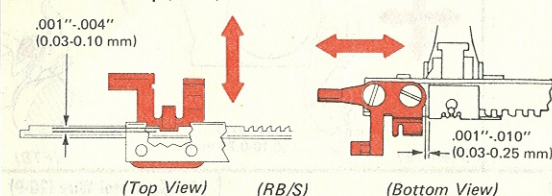

(Top View)

(RB/S)

(Bottom View)

343 Margin Pitch Link Guide Bracket (10-25)  
12-Pitch Mode

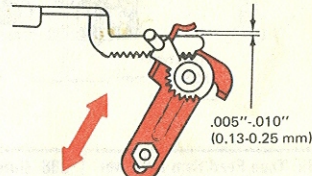

344 Margin Rack Gear (10-29)

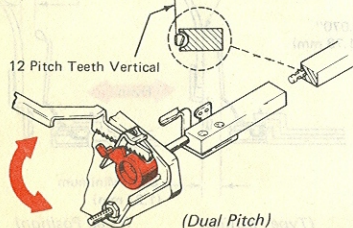

Hold Rail To Right.  
Remove Play In Rack To Left

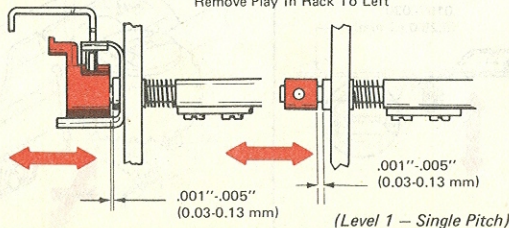

(Level 1 - Single Pitch)

345 Front Margin Rack Gear Stop (10-25)

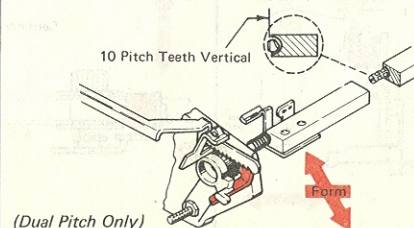

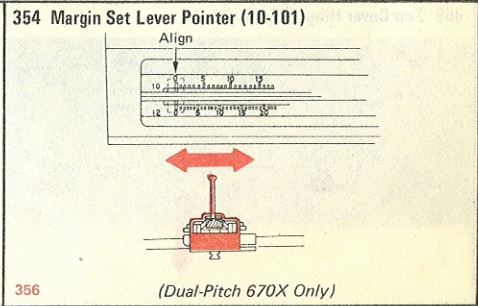
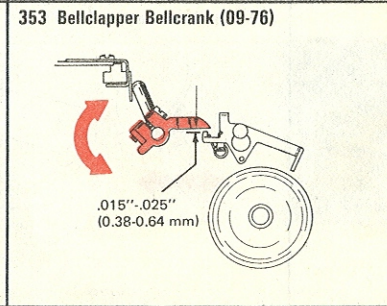
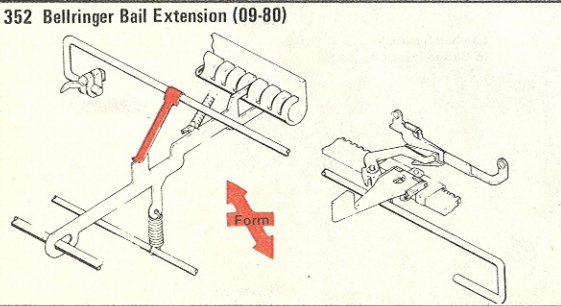
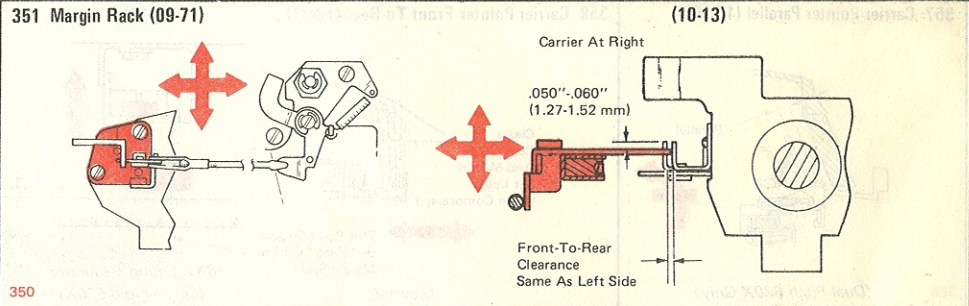
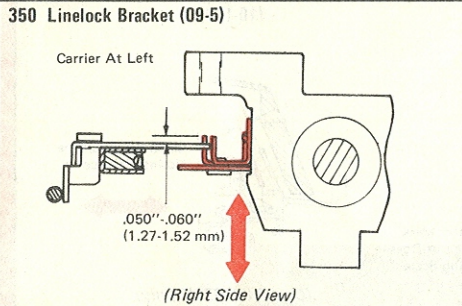
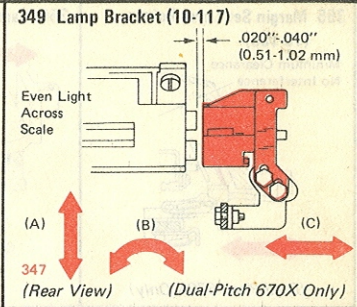
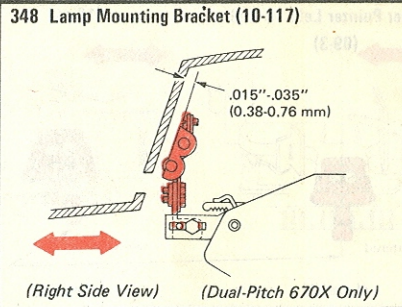
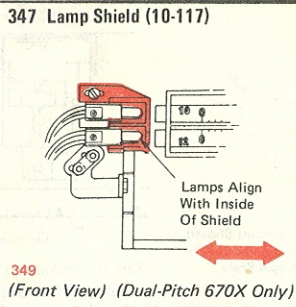
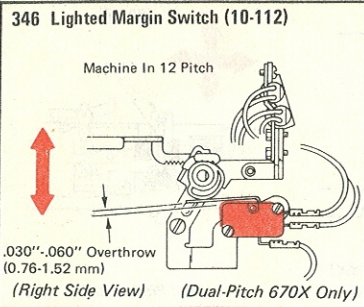

**355 Margin Set Lever Pointer (10-100)**

Minimum Clearance  
No Interference

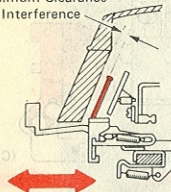

(Dual-Pitch 670X Only)

**356 Carrier Pointer Left To Right (09-3)**

(09-3)

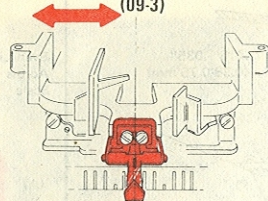

Centered

(Level 1)

(10-40)

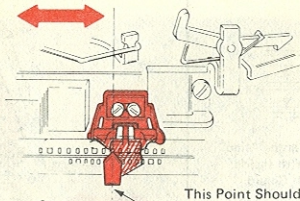

Centered

(Level 2)

This Point Should Be "Zero" On The Margin Scale.

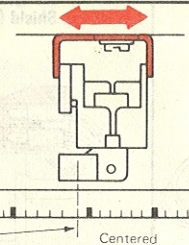

Centered

(Sound Reduction 8XX)  
(Single-Pitch 670X)

(30-18)

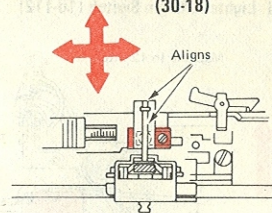

Aligns

(Dual-Pitch 670X)

**357 Carrier Pointer Parallel (10-108)**

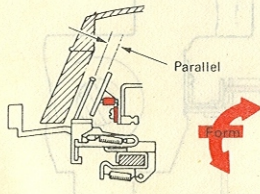

Parallel

358 (Dual-Pitch 670X Only)

**358 Carrier Pointer Front To Rear (10-37)**

Clears Cover  
And Margin  
Set Lever  
When Compressed

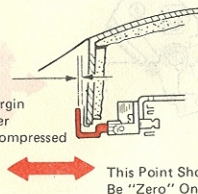

This Point Should Be "Zero" On The Margin Scale.

(Level 2)

(30-19)

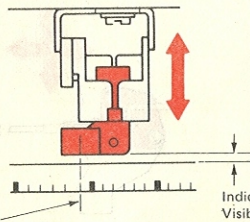

(8XX Sound Reduction)  
(Single-Pitch 670X)

Indicator Mark  
Visible But Does  
Not Rub Scale

(10-107)

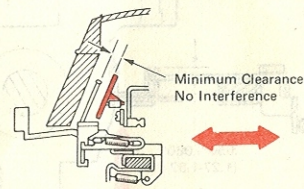

Minimum Clearance  
No Interference

(Dual-Pitch 670X Only)

**359 Top Cover Hinge (04-04) (05-04)**

Top Cover  
Matches Contour  
Of Center Cover

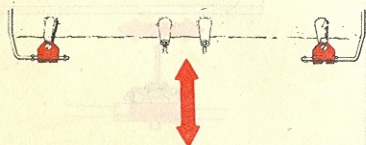

**360 Top Cover Latches (04-83)**

Latched Securely  
In Closed Position

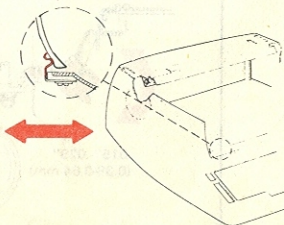

(Level 1)

(05-02)

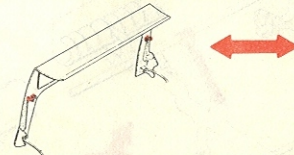

(Level 2)

**361 Cover Mounts (04-251) (04-230)**

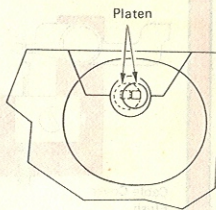
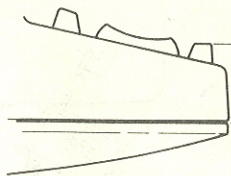
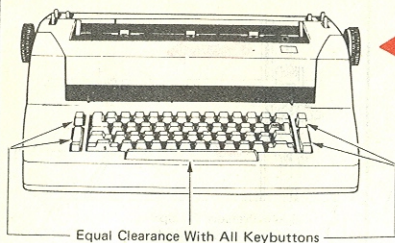

.020"-.030"  
(0.51-0.76 mm)

Paper Deflector

Check All Other Cover Adjustments And Paper Table

**362 Acoustical Filter Hood (30-126)**

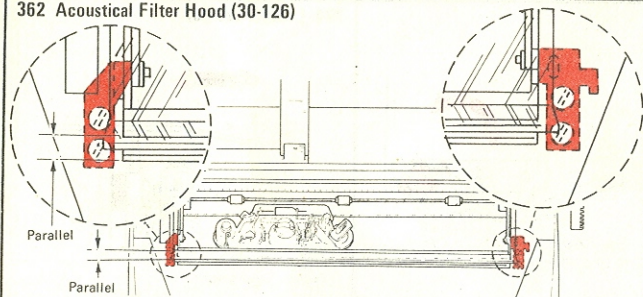

**363 Trigger Link (Dead Key Only) (26-76)**

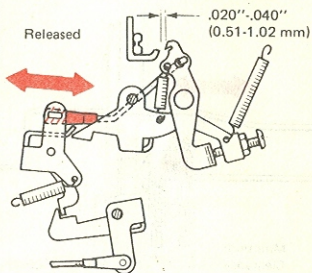

**364 Dead Key Rear Cable Clamp (40-11)**

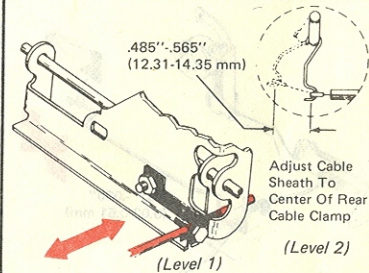

**365 Dead Key Front Cable Clamp (40-11)**

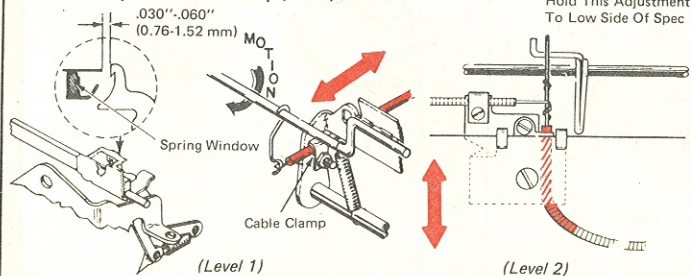

**366 Dead Key Disconnect Indicator (40-29)**

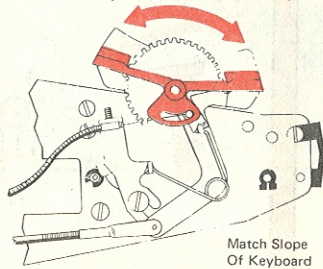

**367 Cable Sheath (40-41)**

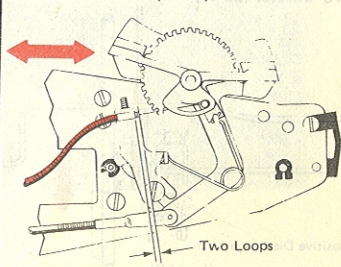

368 Dead Key Disconnect Cable Clamp (40-41)

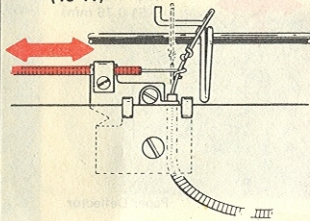

369 Double Index Bellcrank

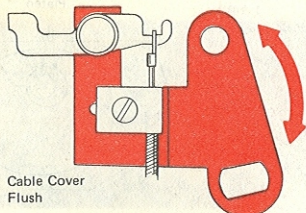

Cable Cover Flush

Adjust To Trip Index Without Binding Off Latch

(Level 1 Only)

370 Side Frame Clamp

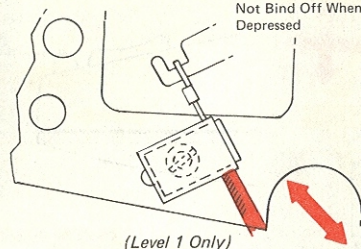

(Level 1 Only)

371 Trip Shaft Clip (20-33)

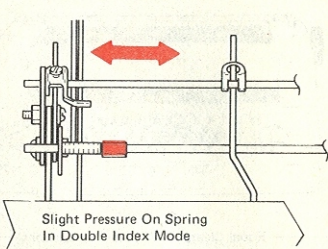

372 Carrier Return Interlock Link (20-35)

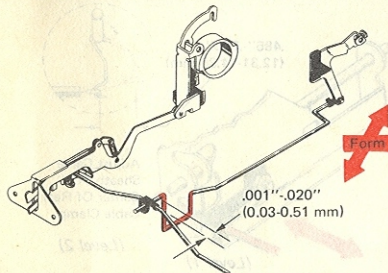

373 Tripper (20-39)

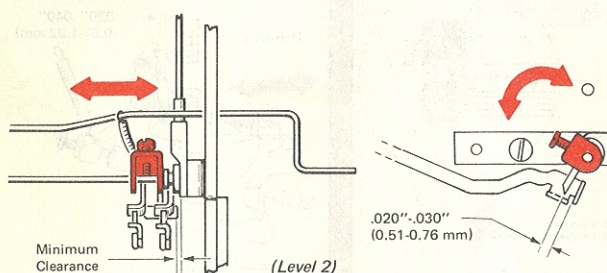

(Level 2)

374 Locator (20-45)

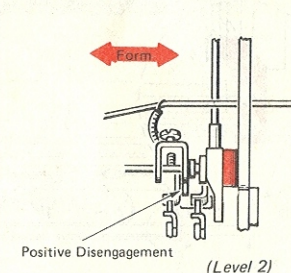

(Level 2)

375 Locator (20-44)

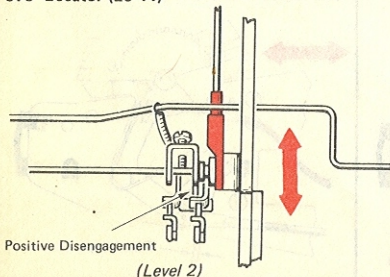

(Level 2)

376 External Ribbon Control Bracket (13-91)

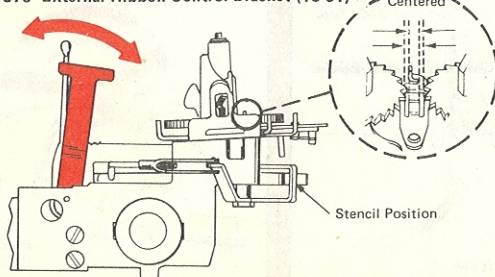

377 Ribbon Lift Control Link (13-63)

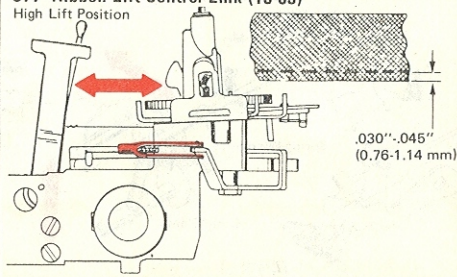

**378 Manual Velocity Control Indicator (21-543)**

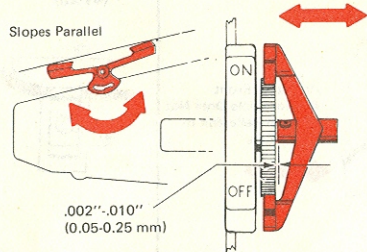

**379 Manual Velocity Low Velocity Link (21-550)**

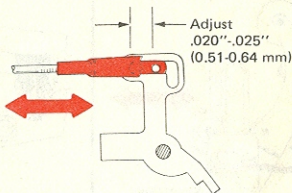

**380 Manual Velocity Control Link (21-546)**

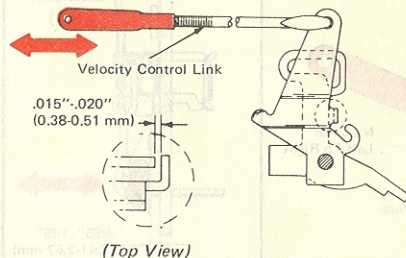

**381 Platen Core Lateral Position (49-07)**

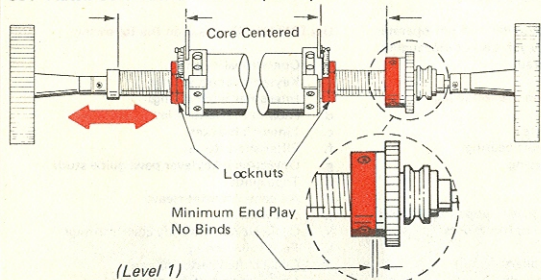

**(49-109)**

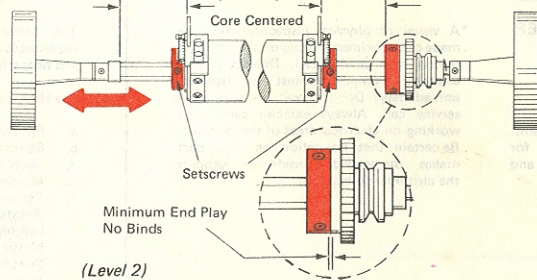

**382 Pinwheel (49-08)**

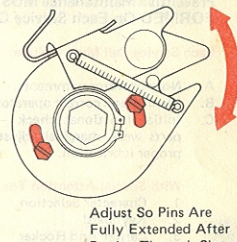

**383 Pinwheel Paper Guide (49-105)**

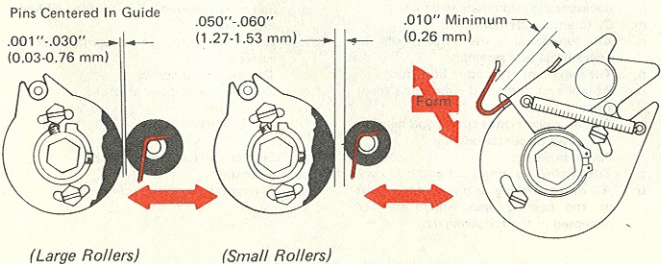

**384 Cardholder (49-21)**

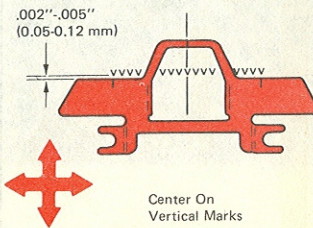

**385 Cardholder Mounting Bracket (22-164) (22-167)**

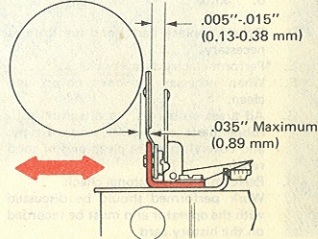

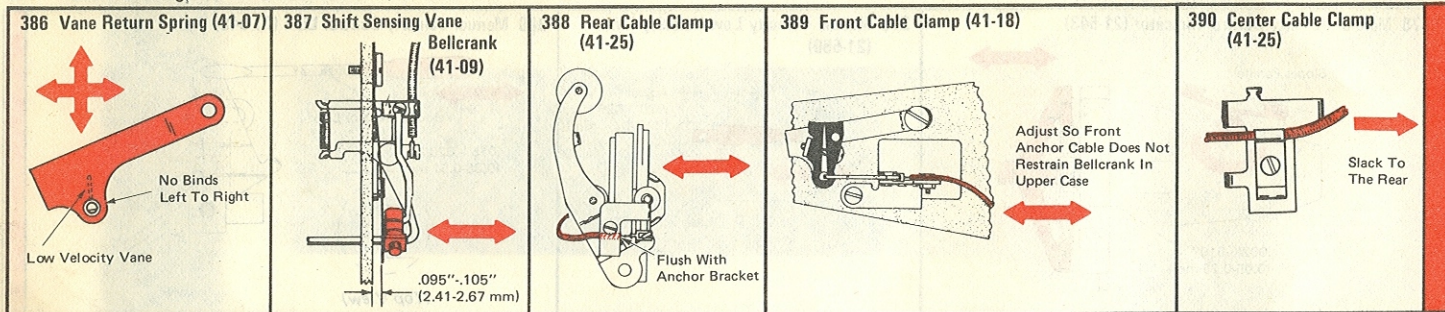

**SERVICE CALL PROCEDURE**

**Preventive Maintenance MUST BE PERFORMED On Each Service Call.**

**Each Service Call Must Include:**

- A. Note operator comments.
- B. Identify and correct operator complaint.
- C. Initial functional check — Look for parts wear, marginal adjustments, and proper lubrication.

**With Special Attention To:**

- 1. Character Selection
- 2. Keyboard
- 3. Carrier And Rocker
- 4. Cycle Shaft/Gear Train
- 5. Operational Area (Carrier Return, Backspace, Tab, Spacebar, Index)
- 6. Shift
- D. Repair, replace parts, and lubricate as necessary.
- E. \*Perform electrical safety check.
- F. When necessary, remove covers and clean.
- G. All areas visible to the operator (e.g., rubber parts, cardholder, element/type, and covers) must be clean and in good repair.
- H. Perform final functional check.
- I. Work performed should be discussed with the operator and must be recorded on the history card.

\*A visual or physical inspection must be made of the primary wiring on the machine during each service call. **Defects in any electrical component must be replaced immediately!** Do not wait until the next service call. Always exercise care when working on electrical areas of the machine. Be certain that no action on your part makes the product unsafe or exposes the customer to hazards.

**LUBRICATION**

The "Electric" Typewriter will not operate dependably and reliably if it is not thoroughly and properly lubricated.

**Use IBM No. 10 oil on the following:**

- a. Print shaft wipers
- b. Selector cam shaft bearing
- c. Margin rack bearing
- d. Margin stops
- e. Carrier shoe
- f. Rotate detent guide, upper and lower ball sockets, tilt detent pivots
- g. Motor
- h. Selection bail rollers
- i. Index pawl assembly
- j. All links and clevises at both ends
- k. Ribbon feed and reverse plate
- l. Backspace intermediate lever
- m. Differential assemblies
- n. All functional parts and pivots in operational box assembly
- o. Tilt arm pivot and rotate link stud
- p. Rotate arm pivot and rotate link pivot studs
- q. Carbon ribbon drive spring and bearing
- r. Power frame center bearing
- s. Platen bushings
- t. Tilt latch mounting stud and bellcrank
- u. All other rotating or pivoting members at the bearing area which are not excepted in the following lists:

**Use IBM No. 23 grease on the following:**

- a. Operational ratchets
- b. Keylever return springs
- c. Interposer latch springs
- d. Ribbon lift control lever
- e. Linelock bracket
- f. Filter shaft flutes
- g. Operational keylever pawl guide studs
- h. Tape guide
- i. All cams on print sleeve
- j. Ball joint
- k. Cycle clutch and shift clutch springs
- l. Feed roll bearing
- m. Cycle clutch restoring cam
- n. Low velocity latch contacts
- o. All sliding parts not excepted
- p. All selective ribbon takeup gears
- q. Selective ribbon lift guide sliding members
- r. Correcting tape feed bellcrank latching surface
- s. Torque limiter spring
- t. Element (or silicone grease)

**DO NOT LUBRICATE:**

- a. Shift brake (braking surface)
- b. Gear train
- c. Carrier return and tab pinions

**FUNCTIONAL CHECK****MISCELLANEOUS**

1. Visual Inspection
2. ON/OFF Switch, Keyboard Lock
3. Margin Set
4. Margin Release
5. Linelock And Bell
6. Scales And Carrier Indicator
7. Switch Pitch Lever (Dual Pitch)
8. Index
9. Shift Lock
10. Margin Lights

**PAPER HANDLING**

1. Paper Insertion
2. Paper Release
3. Multiple Copy Control
4. Detent Release
5. Platen Variable

**CARRIER MOVEMENT** (Check all items in both pitches on dual-pitch machines.)

1. Spacebar And Escapement
2. Half Backspace
3. Backspace
4. Carrier Return
5. Express Backspace
6. Tab

**RIBBON OPERATION**

1. Ribbon Feed
2. Ribbon Lift Pattern
3. Ribbon Path And Tracking
4. Stencil Position
5. Ribbon Reverse (Fabric Ribbon)

**PRINT**

1. Strike Up — Check For:
  - a. Impression
  - b. Selection
  - c. Alignment
  - d. Keyboard Touch
  - e. Shift
2. Repeat Character
3. Impression Control

**CORRECTING MECHANISM**

1. Type several characters.
2. Depress correcting key.
  - a. Carrier should backspace once.
3. Restrike last character.
  - a. Character removed (lift-off tape) or character covered (cover-up tape)
  - b. No escapement
4. Type new character.
  - a. Same position as original character.
  - b. Normal escapement and print should resume.
5. Repeat steps 1 through 4.
  - a. No overlap of characters on correcting tape.

**ELECTRICAL SAFETY CHECK**

For both Per Call and Service Agreement machines, a visual or physical inspection must be made of the primary wiring on the machine during each service call.

**VISUAL CHECK FOR ELECTRICAL HAZARDS**

1. Linecords that have become damaged must be replaced.
2. Wires that are cut, rubbing on mechanical parts, or loose in the machine, must be replaced or relocated. Use cable tie or something similar to hold loose wires.
3. Whenever a switch cover, wire retainer, or safety shield has been removed for servicing, it must be reinstalled when service is completed.
4. Wire connections should only be replaced with wire nuts for crimp-on connectors. Neither tape nor insulating splice should be used.
5. Inspect all linecords that pass through holes in metal desks for cuts or markings. When necessary, grommets or tape should be placed over these edges that come in contact with the linecord.
6. Check to ensure:
  - a. that all double-insulation components are installed
  - b. that insulating paper isolates capacitors from a machine frame on two-wire products
  - c. that no parts, such as paper clips, staples, etc., have become jammed between electrical components and the machine frame, grounding that component to the machine frame. Check the particular product CEMs for a description of the required components.
7. Modifications made by customers to their machines, which expose Customer Engineers to electrical hazards, must be reported to your management.

**CAUTION:** Unplug the machine before working on electrical area.

A quick visual check of the electrical components in equipment during each service call will reduce the possibility of exposing a customer or CE to electrical shock. Defects in any electrical component must be replaced immediately! Do not wait until the next service call. Always exercise care when working on electrical areas of the machine. Be certain that no action on your part makes the product unsafe or exposes hazards to the customer.

**BROKEN TAPES CHECK****Rotate Tape**

1. Rotate detent clearance (skirt)
2. Print shaft timing
3. Shift interlock adjustments
4. Defective rotate arm and shift arm pulleys
5. Tape guide
6. Negative latch clearance insufficient
7. Latch links: too long/too short
8. Popping latches
9. Latch angle
10. Broken or sticking rotate spring
11. Binding on non-greased type element
12. Shift arm pulley
13. Chips or defects in rotate pulleys
14. Rotate pulley key
15. Loose screw in differential bracket

**Tilt Tape**

1. Detent to tilt ring clearance
2. Burrs on tilt pulleys
3. Binds in tilt ring
4. Sector gear
5. Print shaft timing
6. Tilt pulley spring (off or broken)
7. Loose detent follower
8. Tilt tape/carrier shoe eccentric stud



STANDARD U.S. TYPE ELEMENTS 7XX 8XX

Tilt Latches Used	Rotate										Type Element Positions	
	R-5	R-4	R-3	R-2	R-1	H O M E	R+1	R+2	R+3	R+4		R+5
T-0		#	&	*	\$	Z	%	¢				Tilt T-0
T-1	X	U	d	C	L	T	N	E	K	H	B	T-1
T-2	M	V	r	A	O	!	'		S	W	.	T-2
T-1, T-2	G	F	;	?	J	+	P	Q	Y	-	.	T-3
	-5	-5	-5	-5	H	R-1	R-2	R-1	R-2	R-1	R-2	Rotate Latches Used
	R-1	R-2	R-2	R-2A	O	M	E	R-2A	R-2A	R-2A	R-2A	

STANDARD U.S. 96 TYPE ELEMENTS

Tilt Latches Used	Rotate										Type Element Positions	
	R-6	R-5	R-4	R-3	R-2	R-1	H O M E	R+1	R+2	R+3		R+4
T-0	?	=		*	\$		@	%	&	3	Z	Tilt T-0
T-1	+	U	K	B	C	E	T	S	I	'	:	T-1
T-2	±	½	h	x	a	n	r	o	d	w	m	T-2
T-1, T-2	[	]	G	L	F	Y	P	Q	J	.	!	T-3
	-6	-6	-6	-6	-6	H	R-1	R-2	R-1	R-2	R-1	Rotate Latches Used
	R-1	R-2	R-2	R-2A	R-2A	O	M	E	R-2A	R-2A	R-2A	

FILL IN FOR OTHER TYPE ELEMENTS 7XX 8XX

Tilt Latches Used	Rotate										Type Element Positions	
	R-5	R-4	R-3	R-2	R-1	H O M E	R+1	R+2	R+3	R+4		R+5
T-0	/	/	/	/	/	/	/	/	/	/	/	Tilt T-0
T-1	/	/	/	/	/	/	/	/	/	/	/	T-1
T-2	/	/	/	/	/	/	/	/	/	/	/	T-2
T-1, T-2	/	/	/	/	/	/	/	/	/	/	/	T-3
	-5	-5	-5	-5	H	R-1	R-2	R-1	R-2	R-1	R-2	Rotate Latches Used
	R-1	R-2	R-2	R-2A	O	M	E	R-2A	R-2A	R-2A	R-2A	

FILL IN FOR OTHER TYPE ELEMENTS

Tilt Latches Used	Rotate										Type Element Positions	
	R-6	R-5	R-4	R-3	R-2	R-1	H O M E	R+1	R+2	R+3		R+4
T-0	/	/	/	/	/	/	/	/	/	/	/	Tilt T-0
T-1	/	/	/	/	/	/	/	/	/	/	/	T-1
T-2	/	/	/	/	/	/	/	/	/	/	/	T-2
T-1, T-2	/	/	/	/	/	/	/	/	/	/	/	T-3
	-6	-6	-6	-6	-6	H	R-1	R-2	R-1	R-2	R-1	Rotate Latches Used
	R-1	R-2	R-2	R-2A	R-2A	O	M	E	R-2A	R-2A	R-2A	

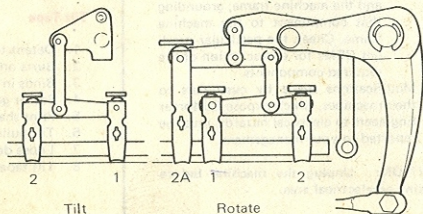

APPLICATIONS RECOMMENDATIONS FOR IBM RIBBONS

IBM General Purpose Fabric Ribbons				
Film Carbon Ribbons (All)				
OCR Film Carbon Ribbon				
Special Film Carbon Ribbon (5122)				
IBM Tech III Ribbon				
IBM Correctable Film Ribbon				

TYPING APPLICATIONS

Correspondence		x		x	x
Statistical Correspondence		x	x	x	x
Specification Writing		x	x	x	x
Medical Reports		x	x	x	x
Executive Correspondence		x		x	x
Routine Correspondence		x	x		x
Typing on Hard-to-Image Originals		x	x	x	x
Ex.: Engineering Drawings					
Optical Character Recognition		x	x		x
Manifolding					x
** Speech Writing		x	x		x
Negotiable Instruments (checks, stocks, etc.)		x	x		x
* Erasable Bond Papers		x	x	x	x

REPRODUCTION APPLICATIONS

Heat Transfer Copying		x	x	x	x	x	x
Transfer Electrostatic Reproduction		x	x	x	x	x	x
Direct Electrostatic Reproduction		x	x	x	x	x	x
Offset Masters (Direct to Plate)		x	x		x	x	x
Offset Masters (Copier Process)		x	x	x	x	x	x
Offset Masters (Photo Process)		x	x		x		x
Stencil Writing (Mimeograph)							
Diazo Process (Ozolid or Bruning)							
Spirit Duplication (Hectographic or Ditto)							

\* The receptivity of the surface of these materials vary widely and care must be used in the selection of a specific material, typestyle and ribbon to produce the best result. When in doubt, let the customer try it first.

\*\* Best results with Orator element are obtained by using IBM Tech III Ribbon.

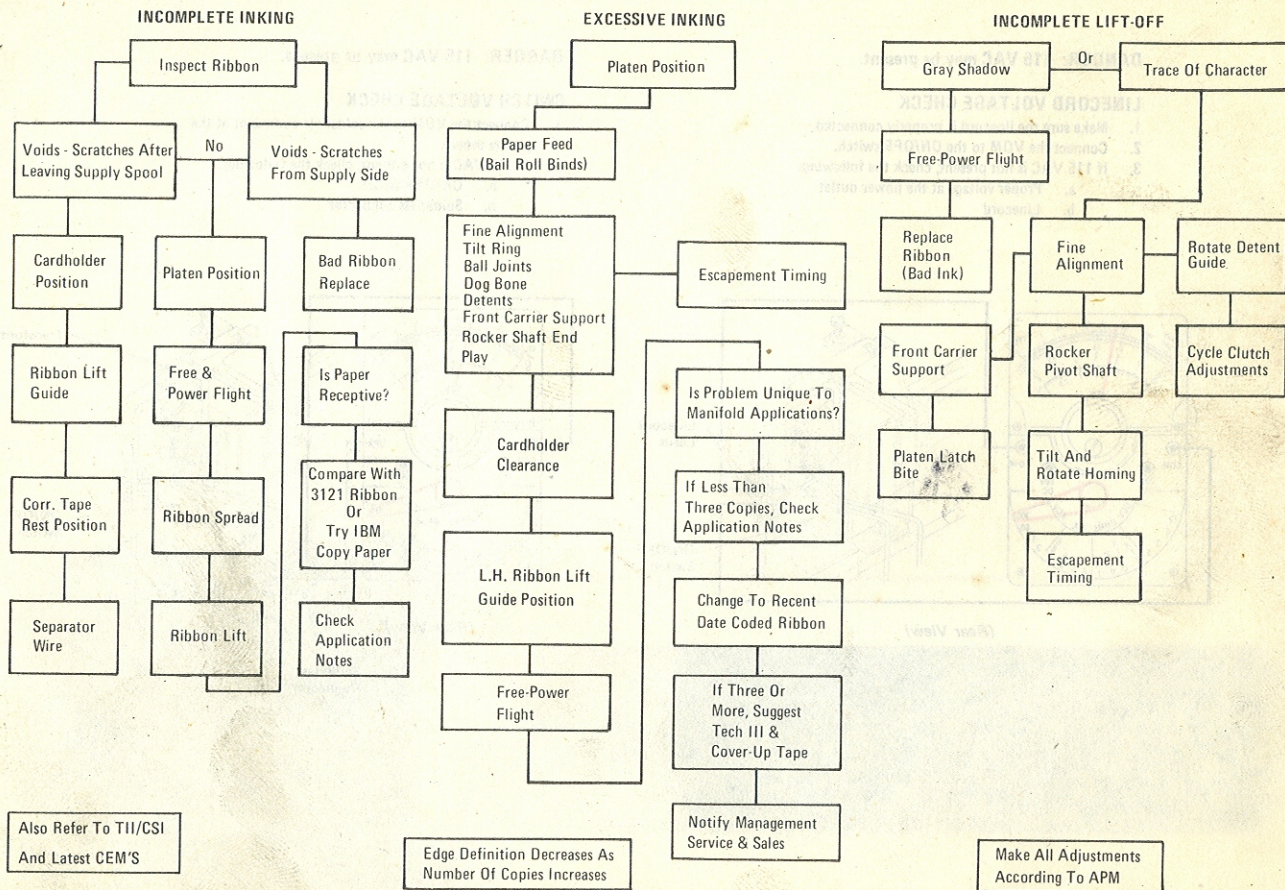

**DANGER: 115 VAC may be present.**

**LINECORD VOLTAGE CHECK**

1. Make sure the linecord is properly connected.
2. Connect the VOM to the ON/OFF switch.
3. If 115 VAC is not present, check the following:
  - a. Proper voltage at the power outlet
  - b. Linecord

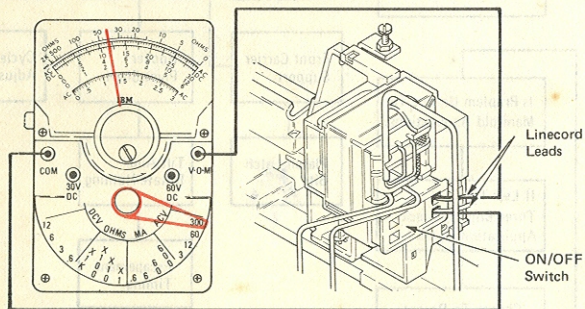

(Rear View)

**DANGER: 115 VAC may be present.**

**SWITCH VOLTAGE CHECK**

1. Connect the VOM to the solderless connector at the points shown.
2. If 115 VAC is not present, check the following:
  - a. ON/OFF switch
  - b. Solderless connector

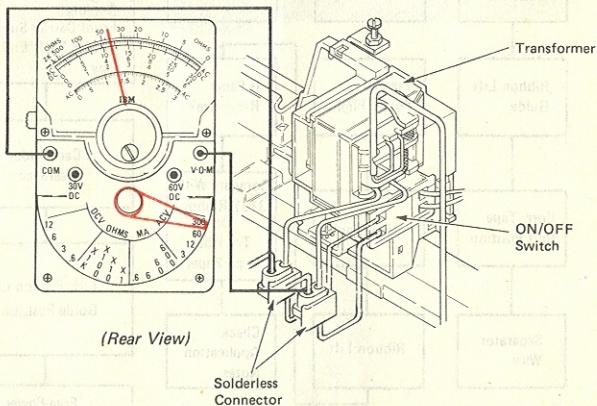

(Rear View)

**TRANSFORMER VOLTAGE CHECK**

1. Connect a VOM to the anchor point and the O/P of the lamp selector switch.
2. If 2.3 to 3.0 VAC is not present, check the following:
  - a. Solderless connector
  - b. Transformer

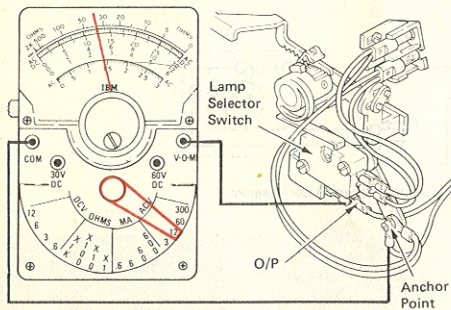

(Left Side View)

**12 PITCH VOLTAGE CHECK**

1. Connect a VOM to the anchor point and to the N/O connector.
2. If 2.3 to 3.0 VAC is not present, check the following:
  - a. Lamp selector switch
  - b. 12-pitch lamp
  - c. 12-pitch lamp wires

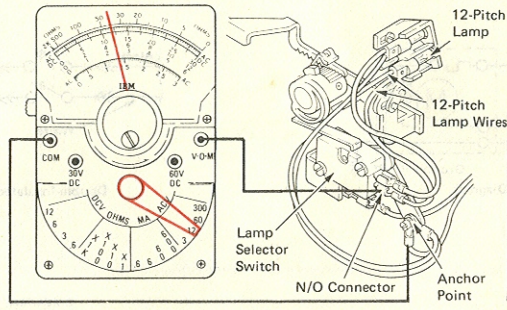

(Left Side View)

**10 PITCH VOLTAGE CHECK**

1. Connect a VOM to the anchor point and to the N/C connector.
2. If 2.3 to 3.0 VAC is not present, check the following:
  - a. Lamp selector switch
  - b. 10-pitch lamp wires
  - c. 10-pitch lamp

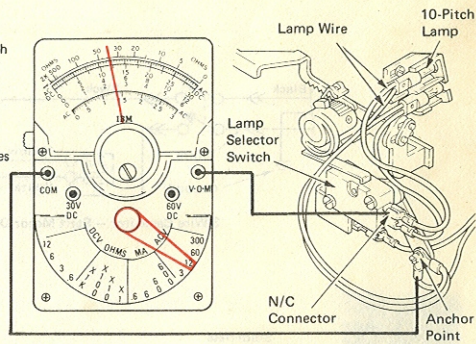

(Left Side View)

MOTOR WIRING DIAGRAMS

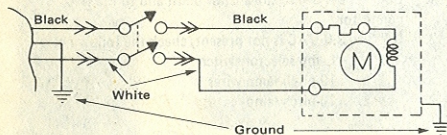

3-Wire Shaded Pole Motor Diagram

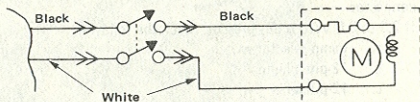

Double-Insulated Shaded Pole Motor Diagram

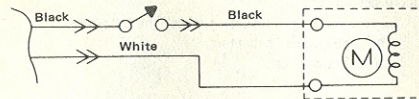

2-Wire Double-Insulated Shaded Pole Motor Diagram  
(Single Pole Switch)

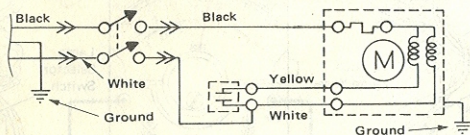

3-Wire Capacitor - Start Motor Diagram

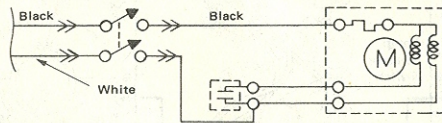

Double-Insulated Capacitor - Start Motor Diagram

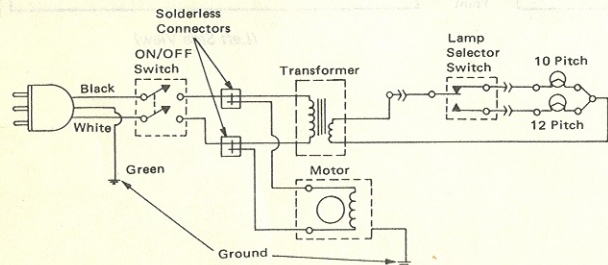

Dual-Pitch 3-Wire Double Insulated Shaded Pole Motor  
"Selectric" III

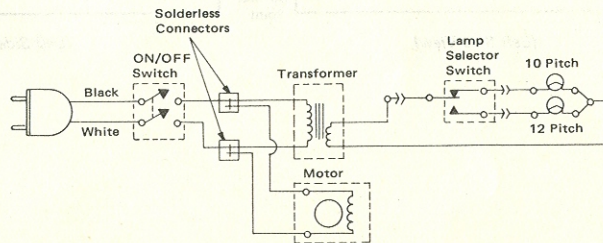

Dual-Pitch 2-Wire Double Insulated Shaded Pole Motor  
"Selectric" III

**BACKSPACE**  
(NR B/S)

MECH. CODE

**01**FOR ROTARY BACKSPACE  
PARTS SEE MECH 24

LEVEL 3

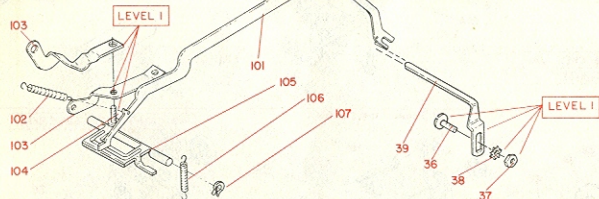
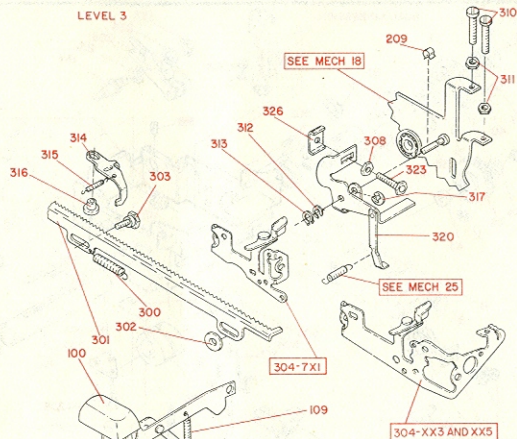

LEVEL 2

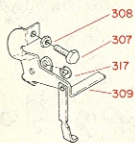

LEVEL 1

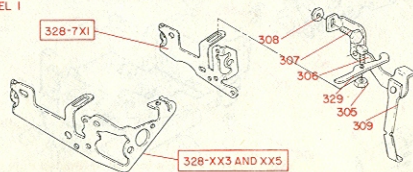
**CARRIER**

MECH. CODE

**02****Predual Impression Machines**

This stud, P/N 1124176, is used as a replacement part on all machines not equipped with dual impression which have the original "non-faced" carriers.

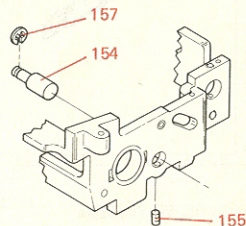
**Predual Impression Machines With New Carrier**

This stud P/N 1164865 and nut, P/N 6503, must be used with a carrier change on all machines not equipped with dual impression. This is necessary because all field replacement carriers are "faced" and do not have a setscrew hole for mounting the original stud.

Part No.	Description
1164865	Stud, Fol. Mtg.
6503	Nut

**Early Dual Impression Machines**

This stud, P/N 1175054, must be used on the early dual impression machines. The follower, P/N 1141619, must also be replaced to ensure compatibility. This procedure is necessary because the early DI carriers were "non-faced." Note: Use washer, P/N 1164290, to reduce side play.

Part No.	Description
1175054	Stud, Fol. Mtg.

**Current Level Machines**

This stud, P/N 1164878 and nut, P/N 6503, can be used on all dual impression carriers that are "faced." It must be used with the new print cam follower, P/N 1141619.

Part No.	Description
1164878	Stud, Fol. Mtg.











MECH. CODE

04

## COVERS &amp; MOUNTING (7XX)

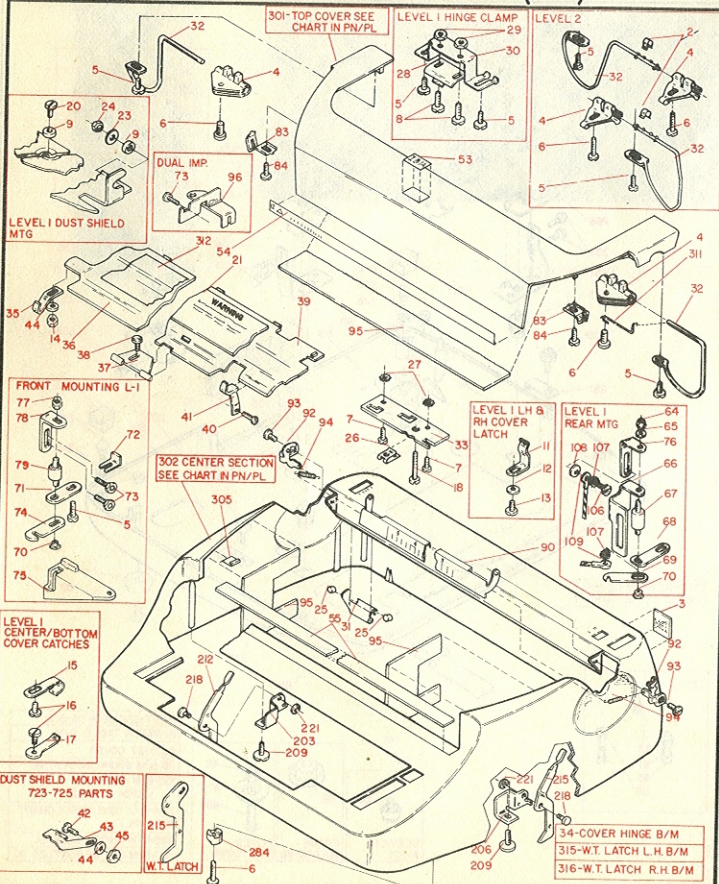

MECH. CODE

05

## COVERS &amp; MOUNTING (8XX) (9XX)

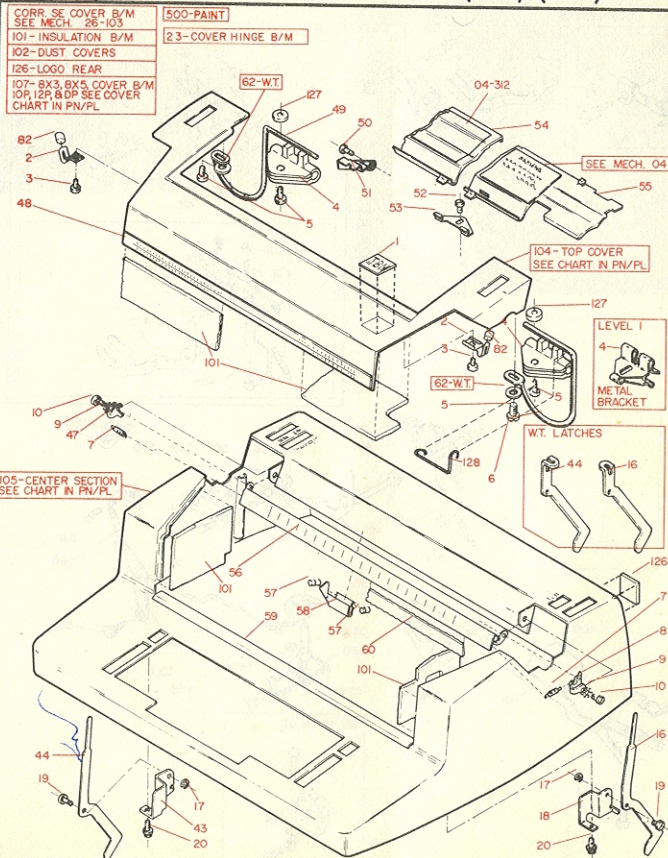

## COVERS &amp; MOUNTING (8XX) (9XX)

MECH. CODE

05

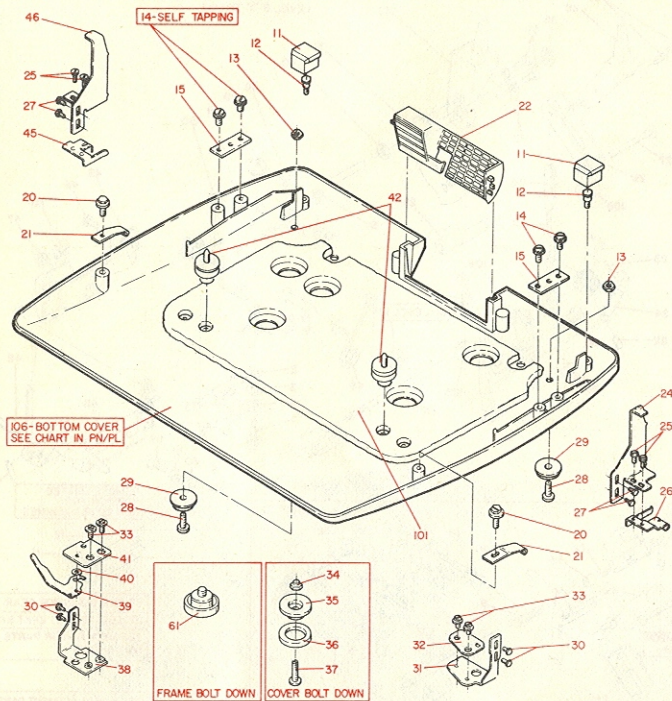

## COVER (670X)

MECH. CODE

05

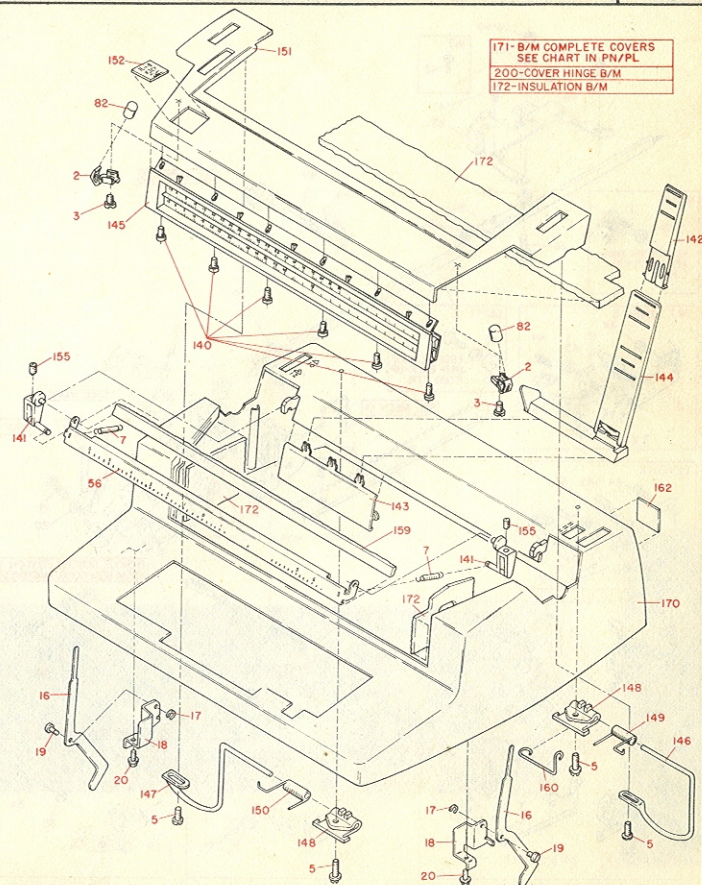



MECH. CODE

MECH. CODE

08

## FRAMES

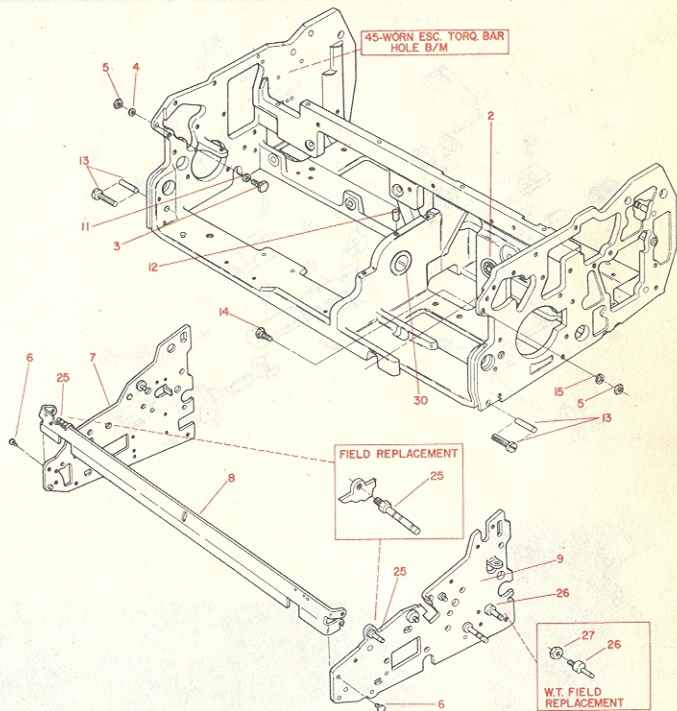

MECH. CODE

09

**MARGINS**  
(NR B/S)

LEVEL 4

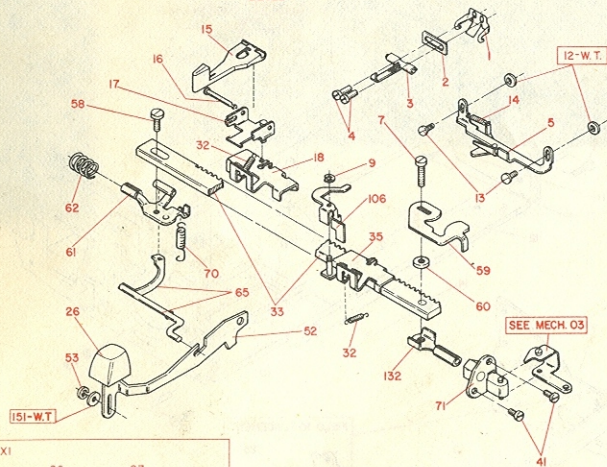

7 X1

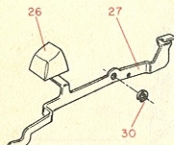

SELECTRIC II

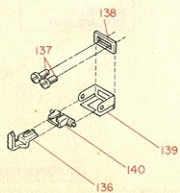

MECH. CODE

09

**MARGINS**  
(NR B/S)

LEVEL 3

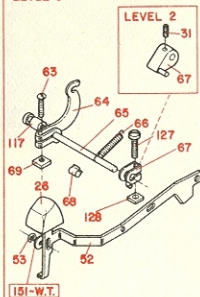

LEVEL 2

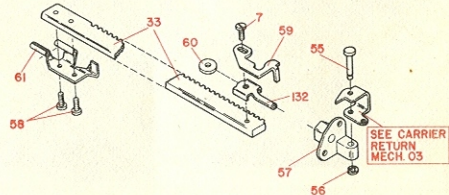

LEVEL 1 LONG CARRIAGE

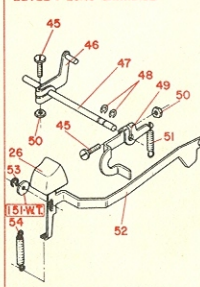

LEVEL 1

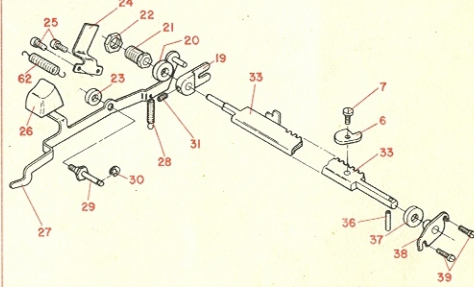

- 105 - B/M CARRIER POINTER 7XX
- 125 - MARGIN LEVER ASM.
- 126 - B/M MARGIN RACK
- 133 - B/M MARGIN PIVOT
- 150 - MARGIN RACK ASM. INCL. REF. 125

**LINELOCK & BELL**

MECH. CODE

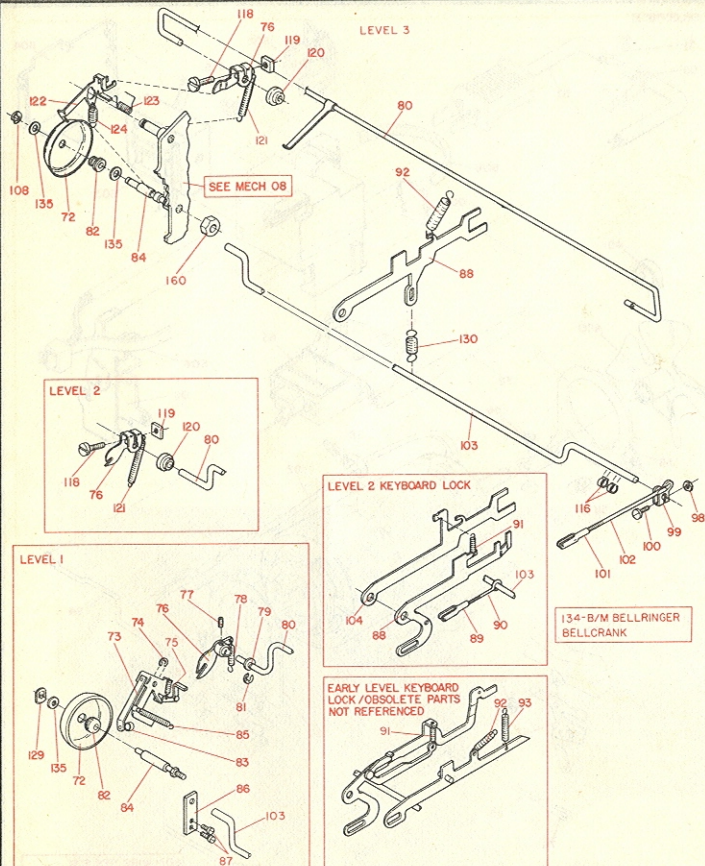
**09****MARGINS (RB/S)**

MECH. CODE

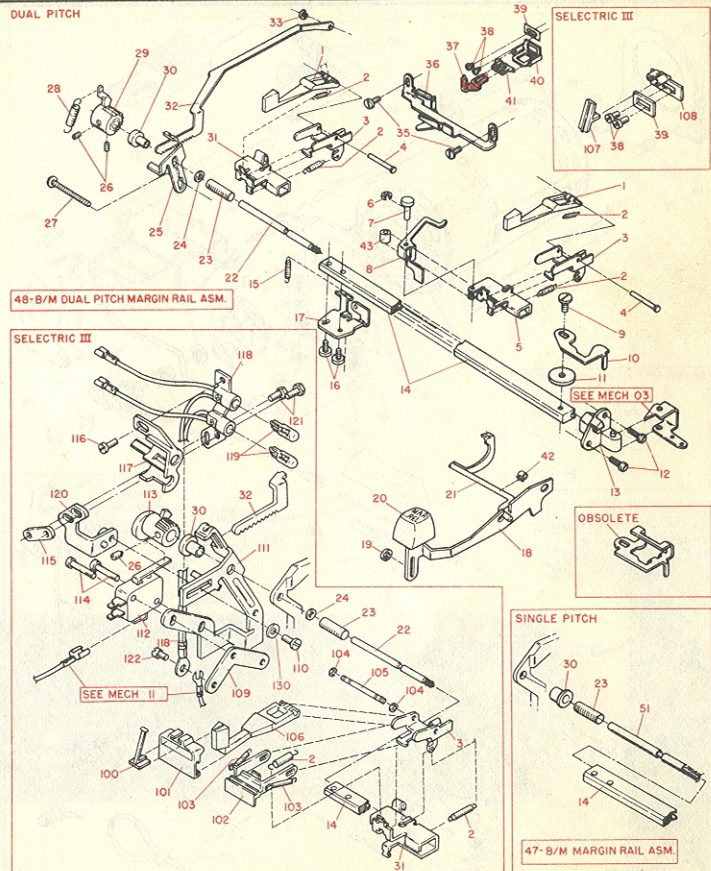
**10**



MECH. CODE  
**11**

**U.S. MOTOR & DRIVE  
(SHADED POLE)**

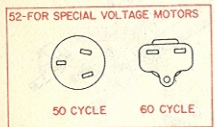
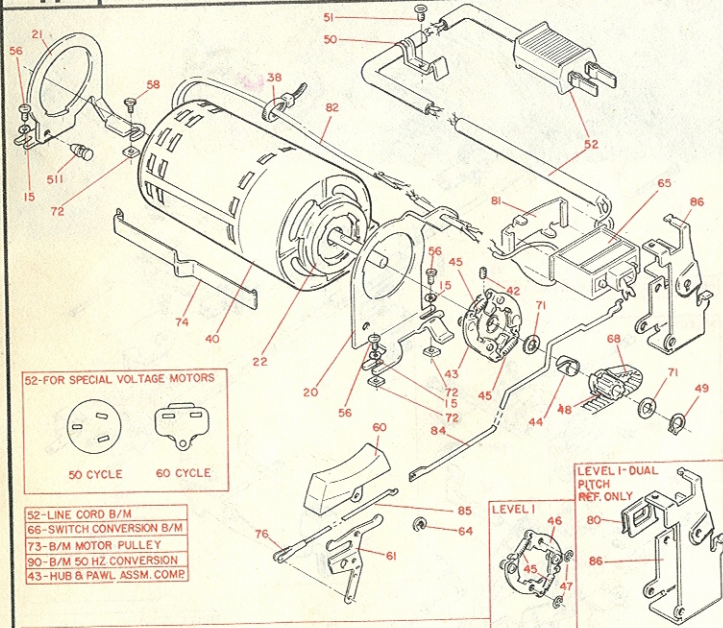

- 52-LINE CORD B/M
- 66-SWITCH CONVERSION B/M
- 73-B/M MOTOR PULLEY
- 90-B/M 50 HZ CONVERSION
- 43-HUB & PAWL ASSM. COMP

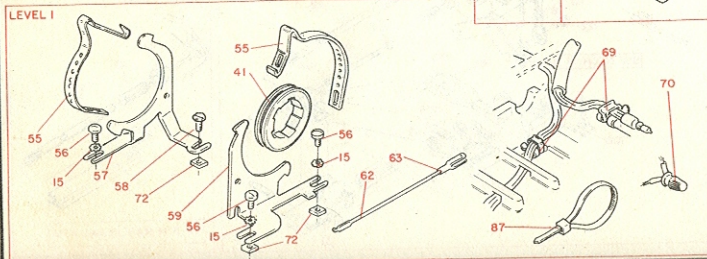

MECH. CODE  
**11**

**U.S. MOTOR & DRIVE  
(SHADED POLE)**

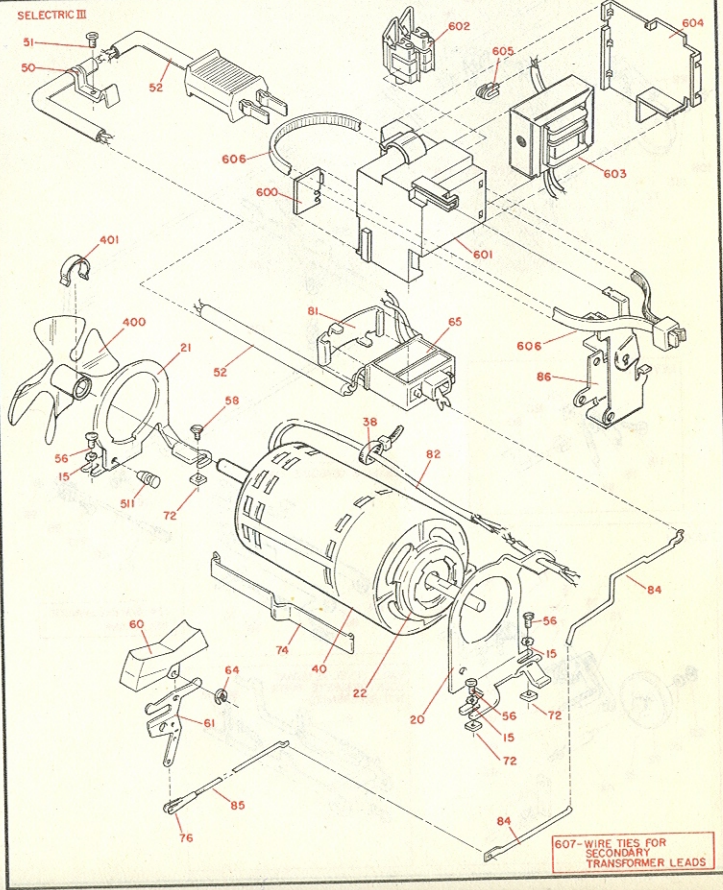

607-WIRE TIES FOR  
SECONDARY  
TRANSFORMER LEADS

# U.S. MOTOR & DRIVE

(CAPACITOR START)

MECH. CODE

11

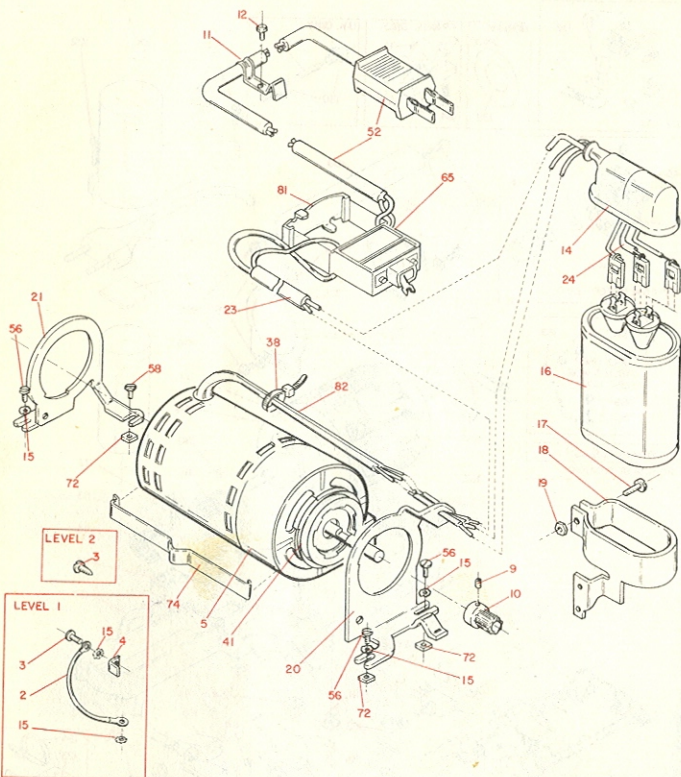

# W.T. MOTOR & DRIVE

(NETHERLANDS - SHADED POLE)

MECH. CODE

11

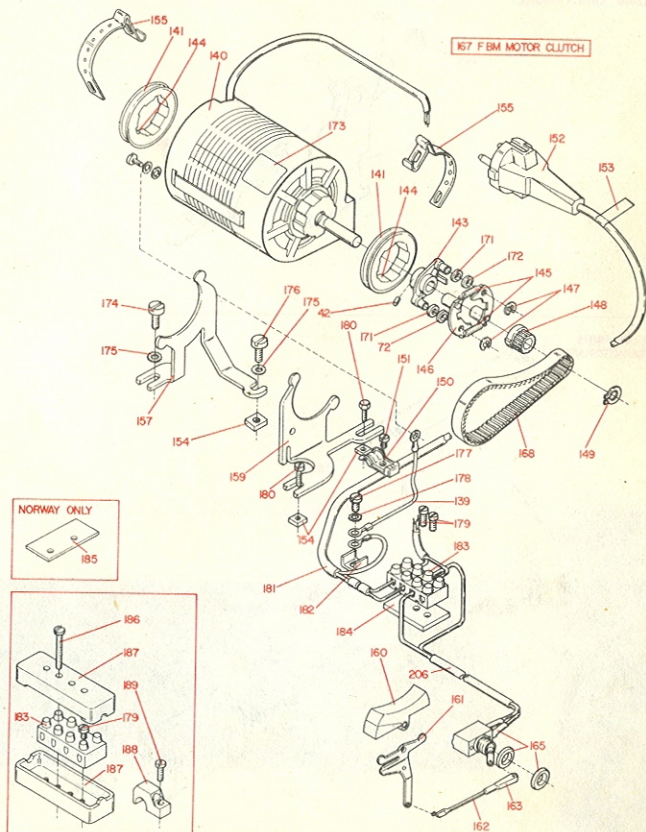

MECH. CODE

11

## W.T. MOTOR

(NETHERLANDS - FIELD USE PARTS)

BI-VOLTAGE SWITCH FRANCE

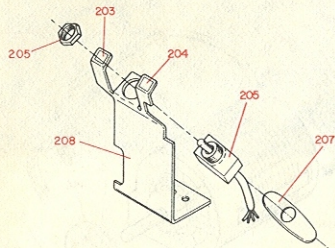
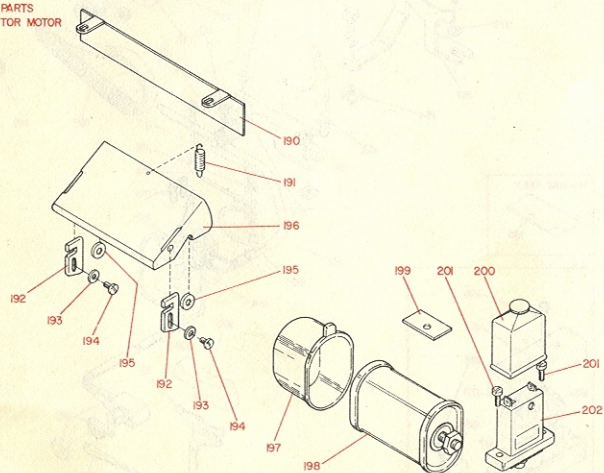
FIELD USE PARTS  
FOR CAPACITOR MOTOR

MECH. CODE

11

## W.T. MOTOR & DRIVE

(NETHERLANDS - DOUBLE INSULATION)

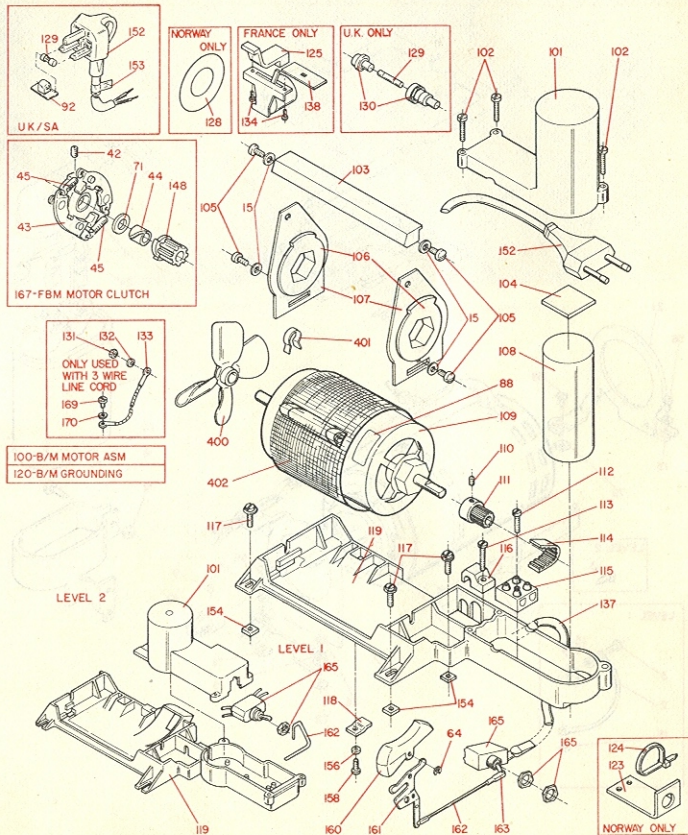

# W.T. MOTOR & DRIVE

(CANADIAN - SHADED POLE)

MECH. CODE

11

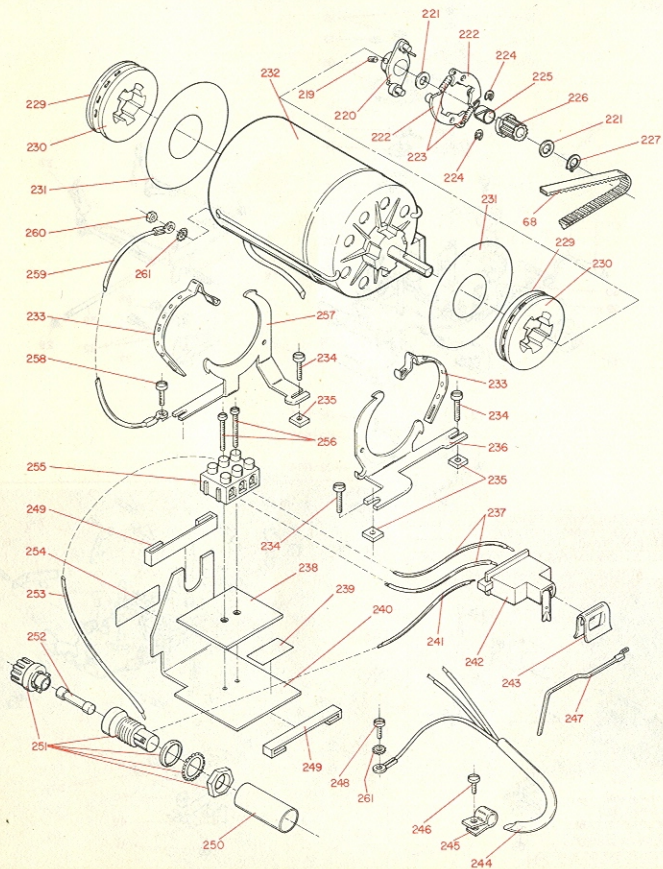

# W.T. MOTOR & DRIVE

(CANADIAN - DOUBLE INSULATION)

MECH. CODE

11

73 - B/M MOTOR PULLEY
360 - LABEL, ADDITIONAL
365 - NOISE REDUCTION PACKAGE
370 - B/M MOTOR

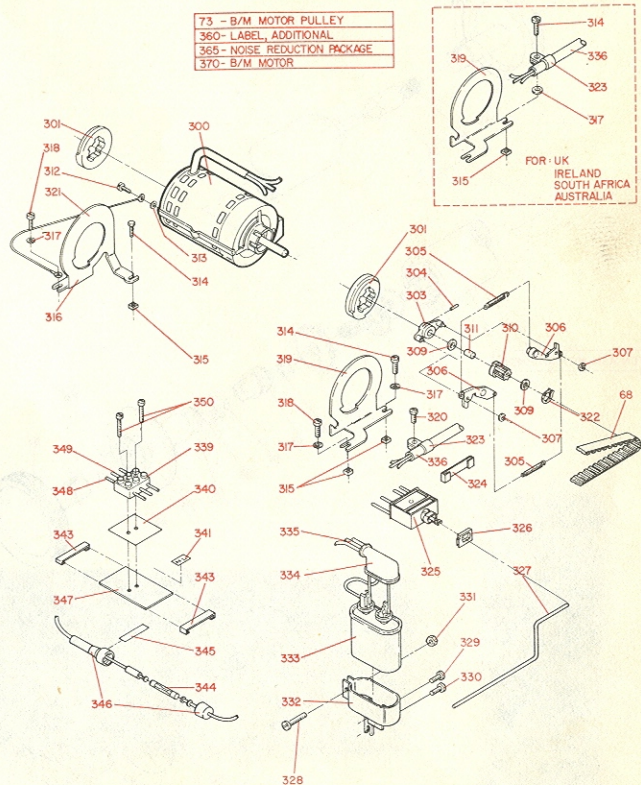

MECH. CODE

12

PLATEN

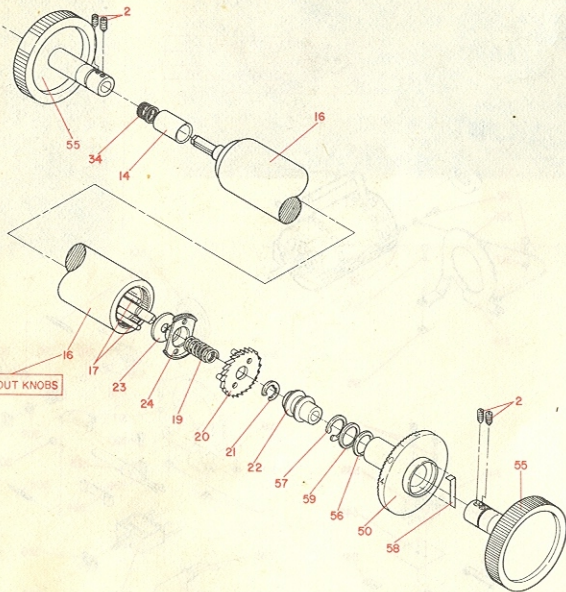

PLATEN ASM WITHOUT KNOBS

"SELECTRIC"

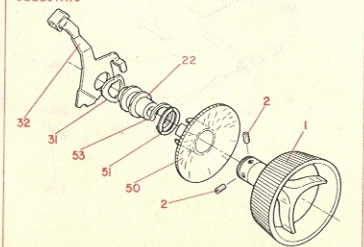

- 25 B/M 24T RATCHET CONVERSION
- 30 B/M 54T RATCHET
- 33 B/M LINE POSITION RESET LEVER

MECH. CODE

13

FABRIC RIBBON

LEVEL 2

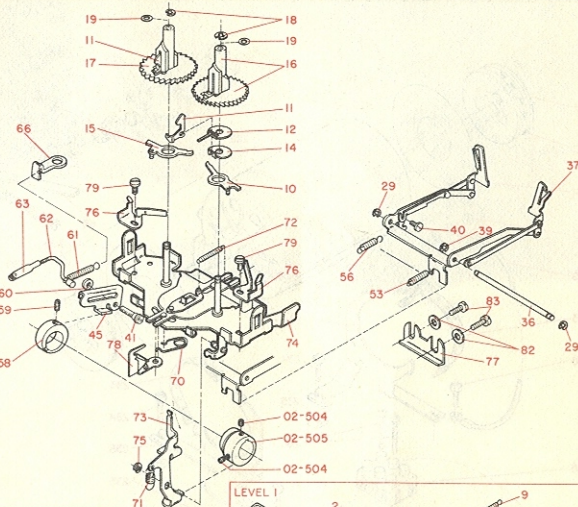

- 64-LEVEL 1 RIBBON FEED ASM
- 80-LEVEL 2 RIBBON FEED ASM
- 81-B/M STENCIL LOCKOUT
- 02-130-B/M CARRIER & ROCKER ASM. 7/84X
- WITH EXTERNAL RIBBON CONTROL
- 02-130-B/M CARRIER & ROCKER FAB RIB COMP

SEE MECH 02

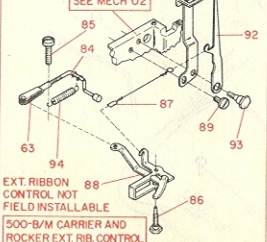

- EXT RIBBON CONTROL NOT FIELD INSTALLABLE
- 500-B/M CARRIER AND ROCKER EXT. RIB. CONTROL

LEVEL 1

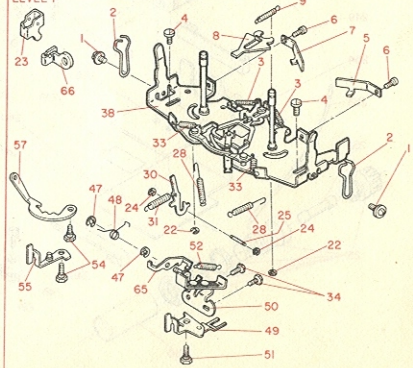

## FILM RIBBON

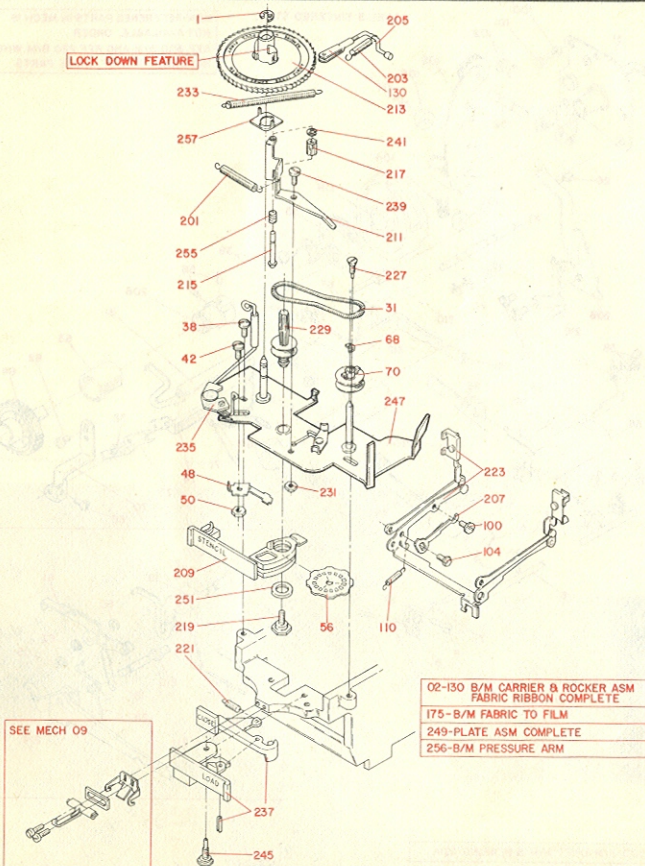
MECH. CODE  
14

## FILM RIBBON

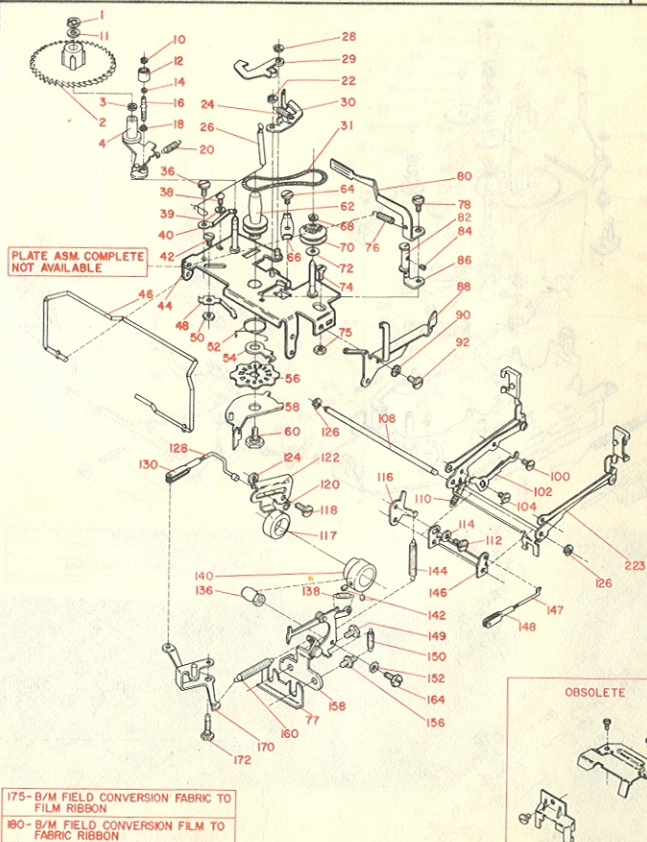
MECH. CODE  
14

MECH. CODE

15

## SELECTIVE RIBBON

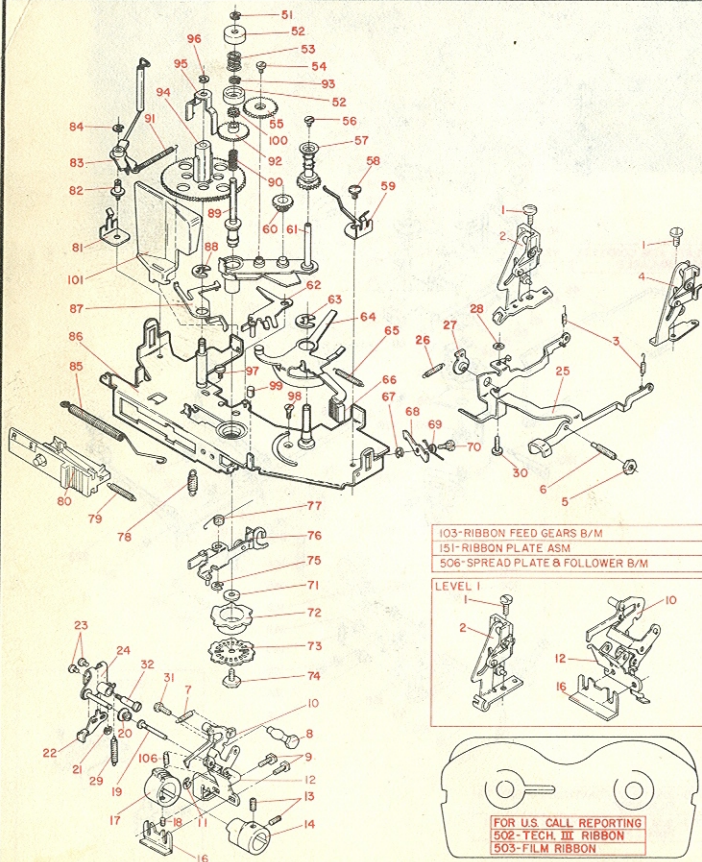

MECH. CODE

16

## SHIFT

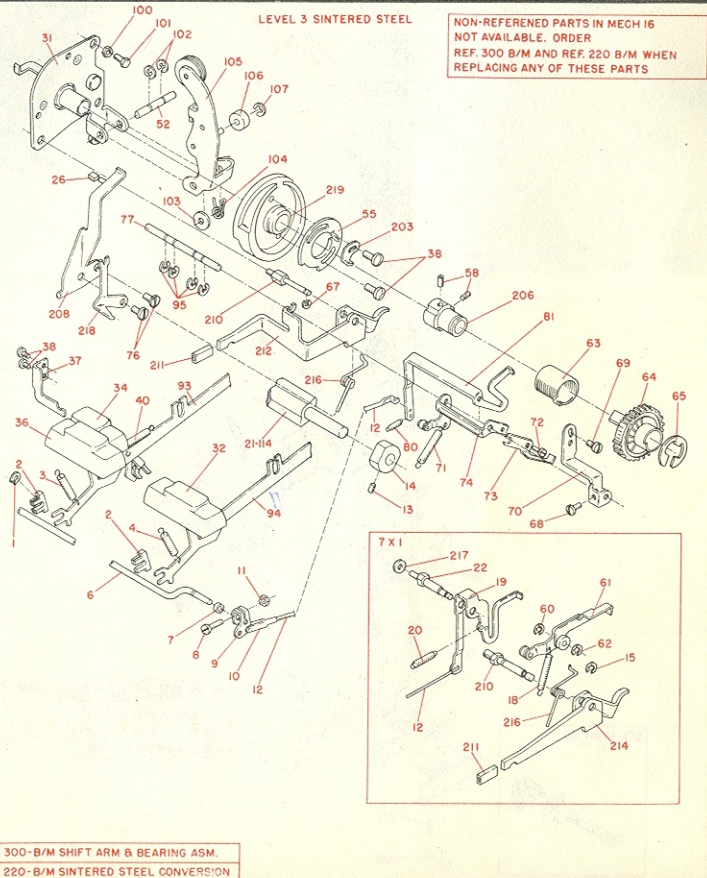

## SHIFT

MECH. CODE  
16

## LEVEL 2 7X1 PLASTIC CAM

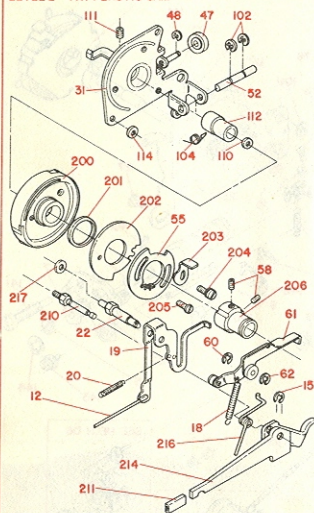

## LEVEL 2 XX3 AND XX5 PLASTIC CAM

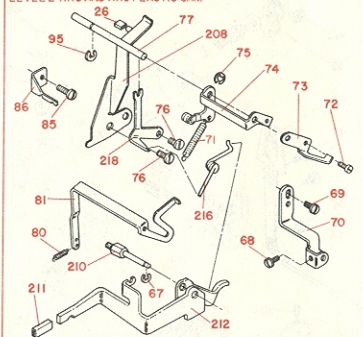

## LEVEL 1 7X1 STEEL CAM

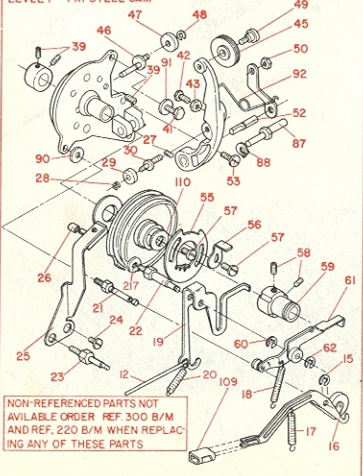

## LEVEL 1 XX3 AND XX5 STEEL CAM

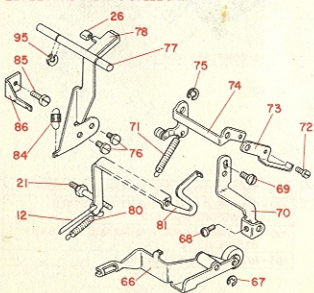

## SPACEBAR

MECH. CODE  
17

## LEVEL 3

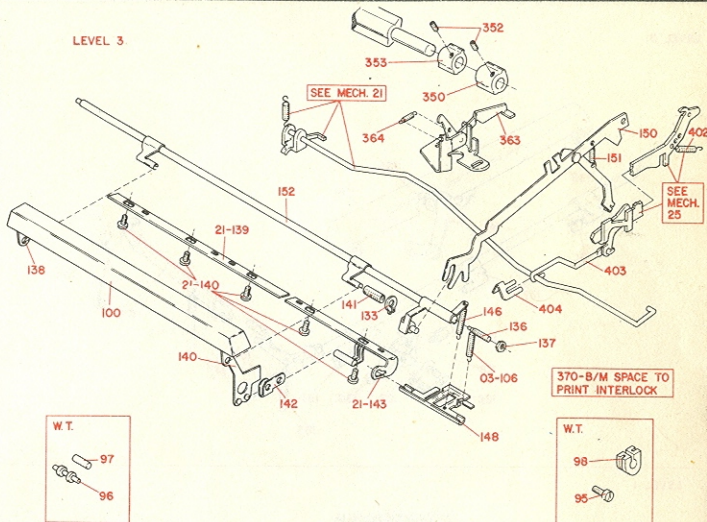

## "SELECTRIC" II TYPEWRITER RB/S

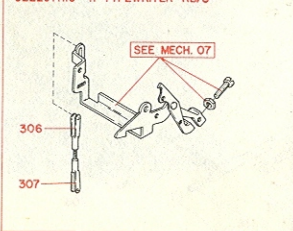





## TAB (NR B/S)

 MECH. CODE  
**18**

### LEVEL 2 TAB LEVER

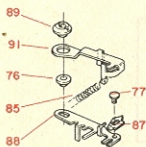

### LEVEL 1 TAB LEVER

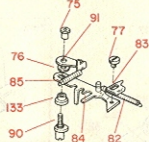

### TAB PULLEY AND BRACKET

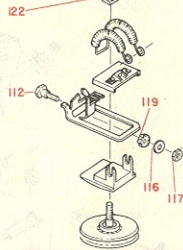

FOR PARTS NOT REFERENCED ORDER  
B/M 130-R-H TRANSPORT PULLEY &  
BRKT ASM. COMPLETE

### 200-B/M TAB KEYLEVER LINE LOCK

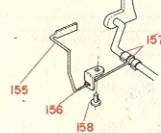

### 7X3-7X5 TAB BELLCRANK LEVEL 1

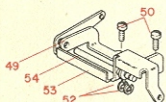

### OBSOLETE PARTS - SEE REF 24

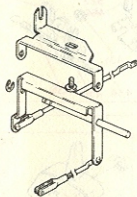

### 7 X 1

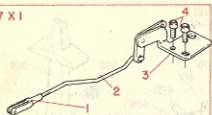

### LEVEL 1

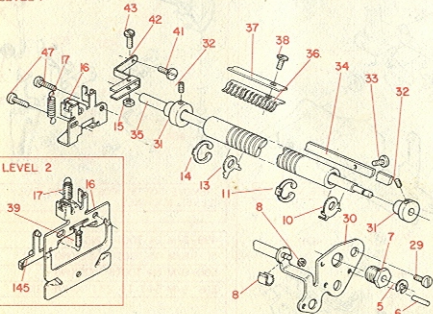

### LEVEL 2

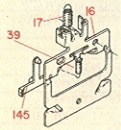

### LEVEL 1 ESCAPEMENT SHAFT

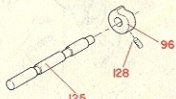

## TAB (RB/S)

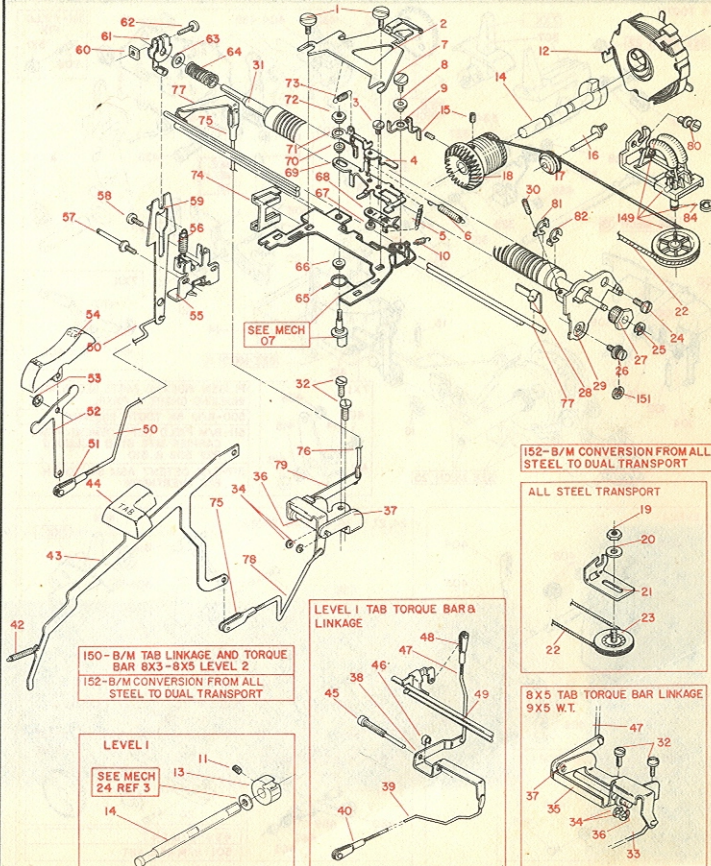
 MECH. CODE  
**19**

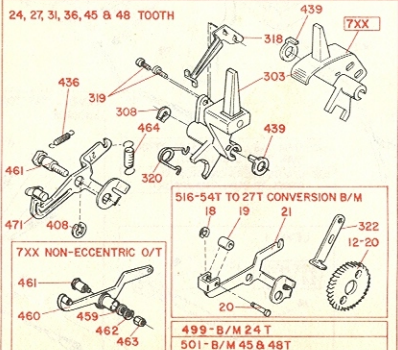
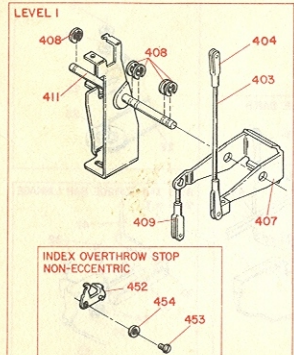
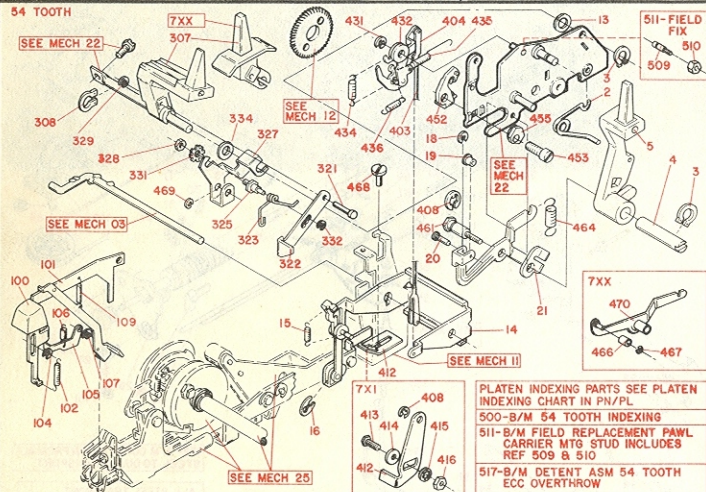
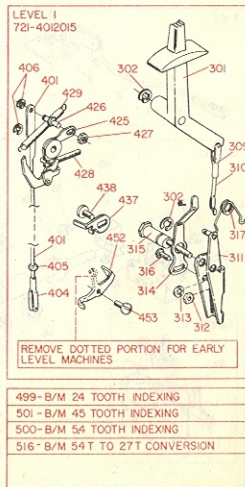
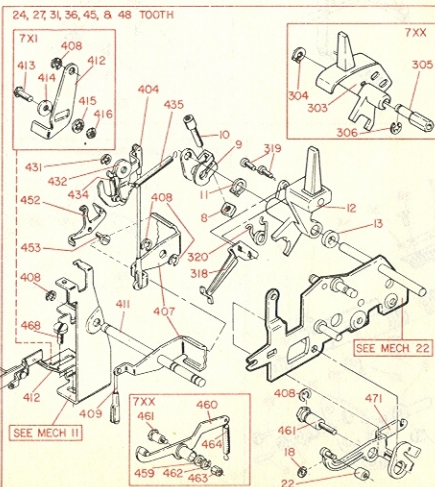
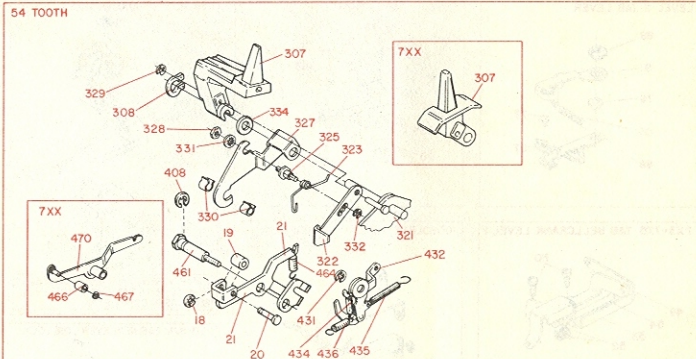
MECH. CODE  
**20****INDEXING  
(A-FRAME)**MECH. CODE  
**20****INDEXING  
(TIE-ROD)**

# INDEXING (DOUBLE)

MECH. CODE  
**20**

LEVEL 2

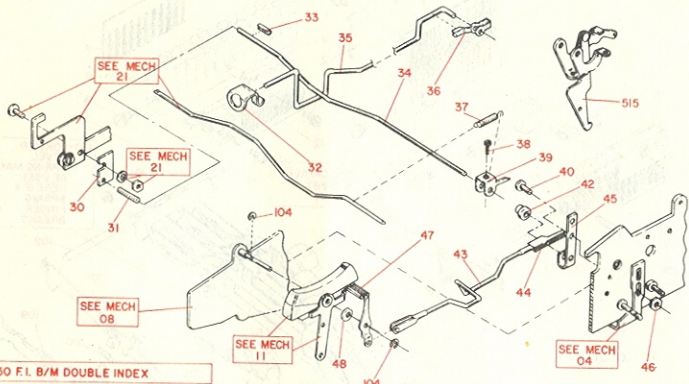

50 F.I. B/M DOUBLE INDEX

LEVEL 3

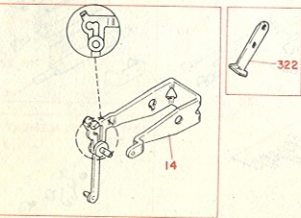
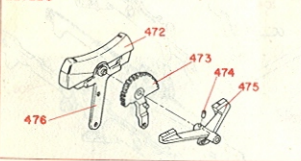

LEVEL 1 - 2, 2 1/2, 3 LINES

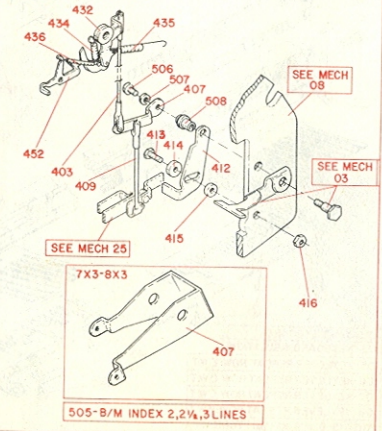

50S-B/M INDEX 2, 2 1/2, 3 LINES

# W.T. INDEXING

MECH. CODE  
**20**

LEVEL 1

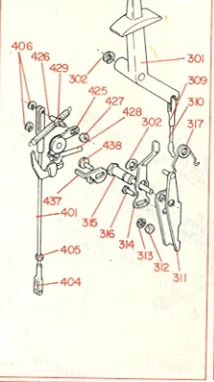

8XX/9XX

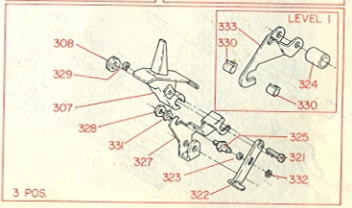
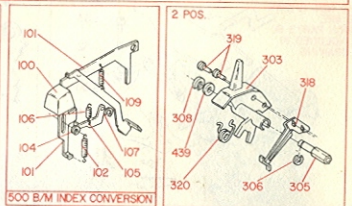
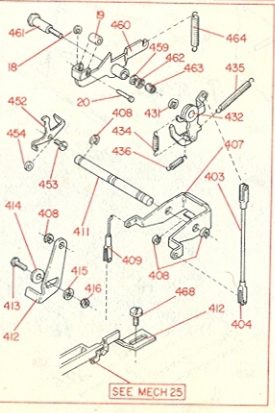
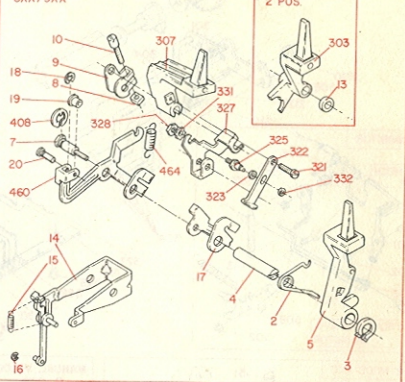

SEE MECH 25

3 POS





MECH CODE

22

### PAPER FEED (A-FRAME)

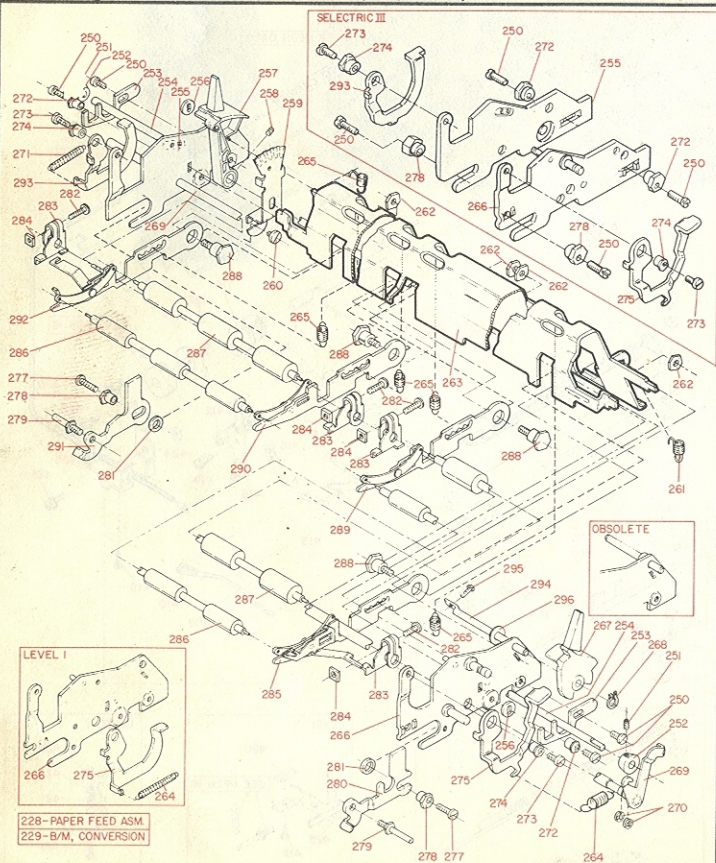

MECH CODE

22

### PAPER FEED (TIE-ROD)

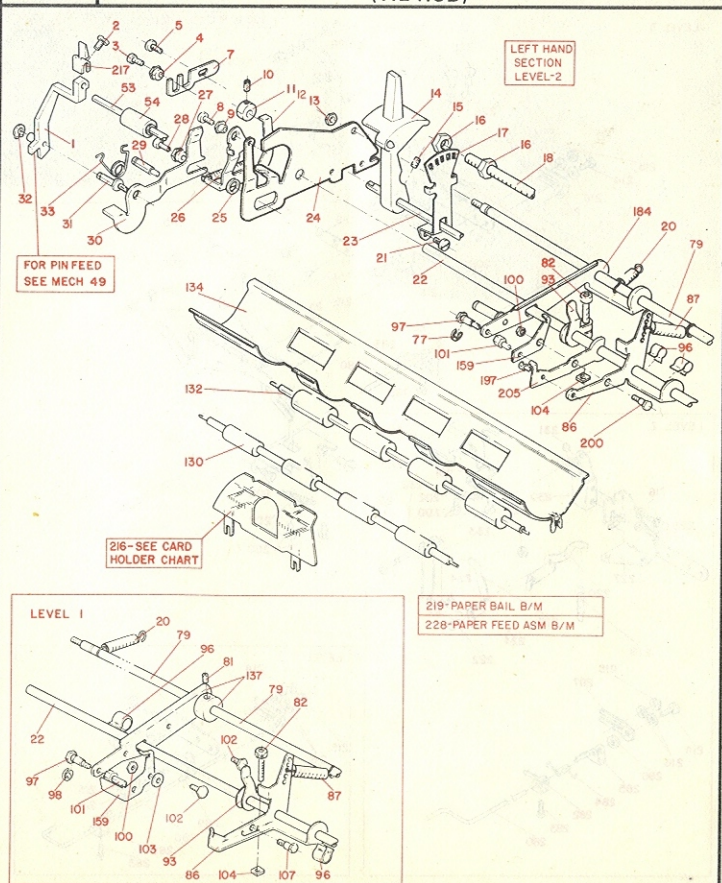

# PAPER FEED (TIE-ROD)

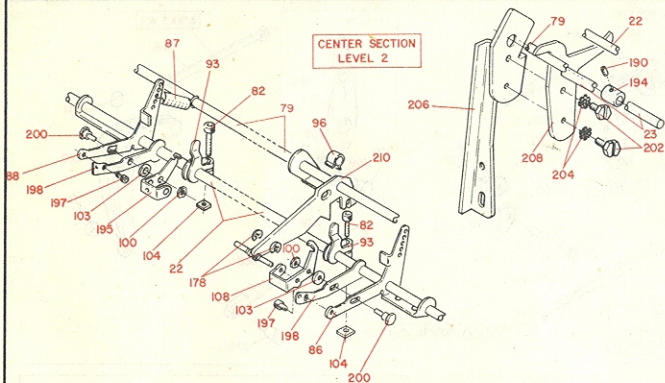
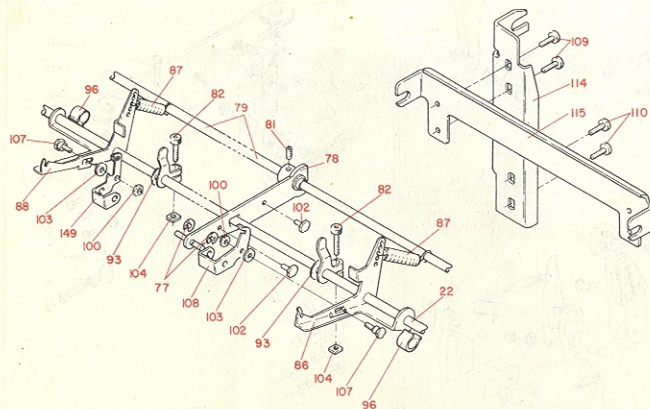
 MECH. CODE  
**22**

**LEVEL 1**

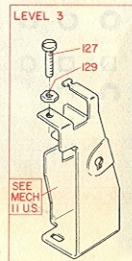
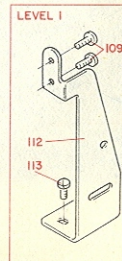
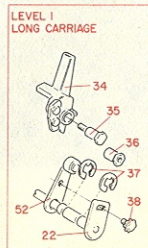
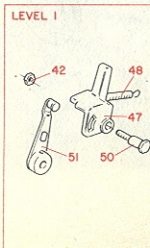
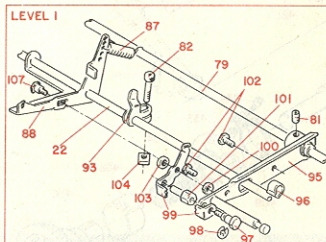
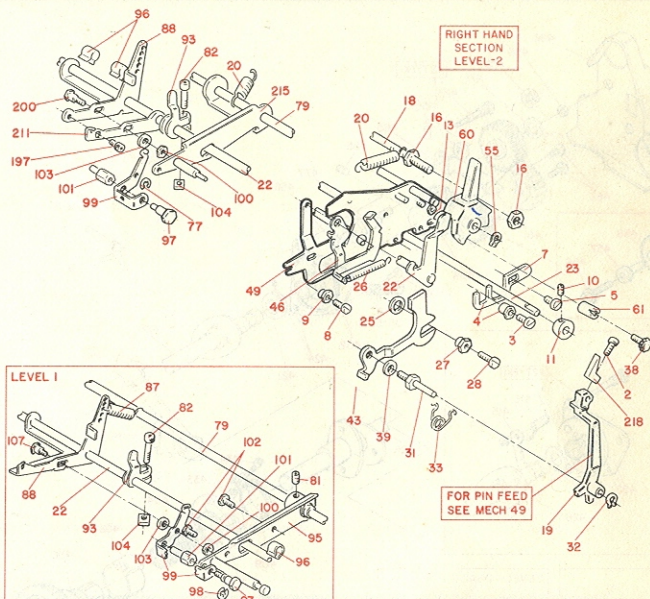
# PAPER FEED (TIE-ROD)

 MECH. CODE  
**22**



MECH. CODE

23

SELECTION

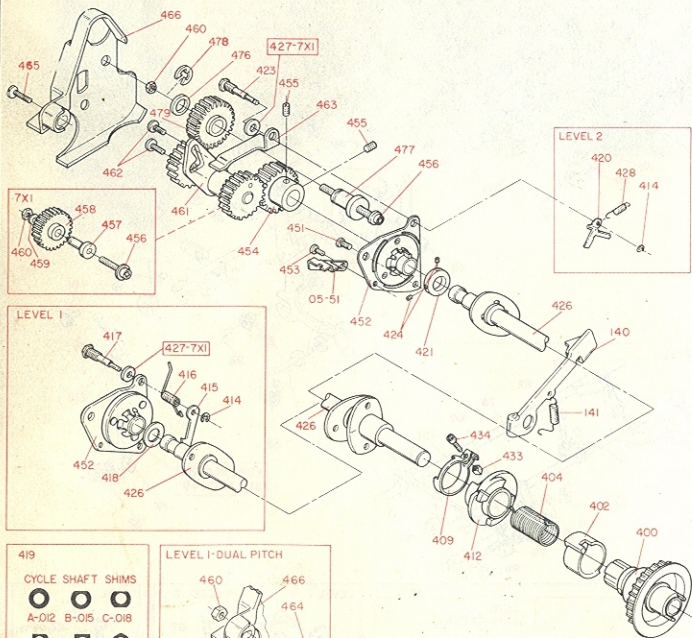

419

CYCLE SHAFT SHIMS

A-.012	B-.015	C-.018
D-.021	E-.033	F-.005
G-.002	H-.005	

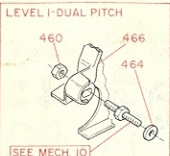

- 435- B/M CYCLE CLUTCH
- 437- B/M CYCLE SHAFT
- 470- B/M GEAR TRAIN
- 500- B/M CYCLE SHAFT L-2 W.T.

MECH. CODE

23

SELECTION

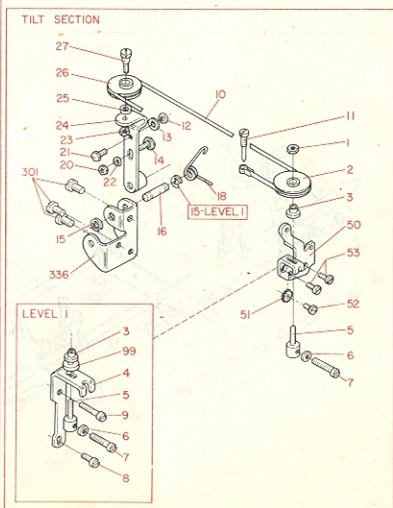
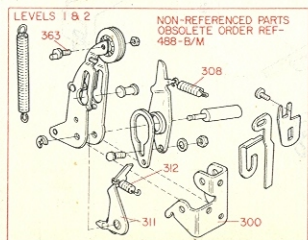
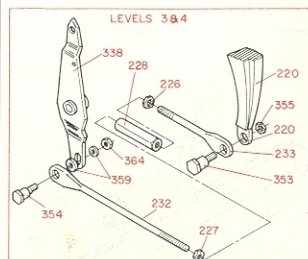
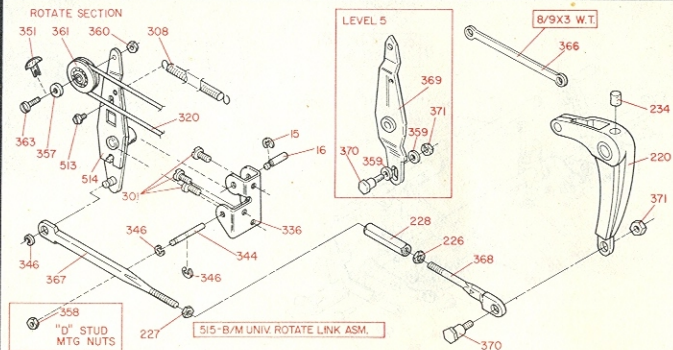

## SELECTION

MECH. CODE

23

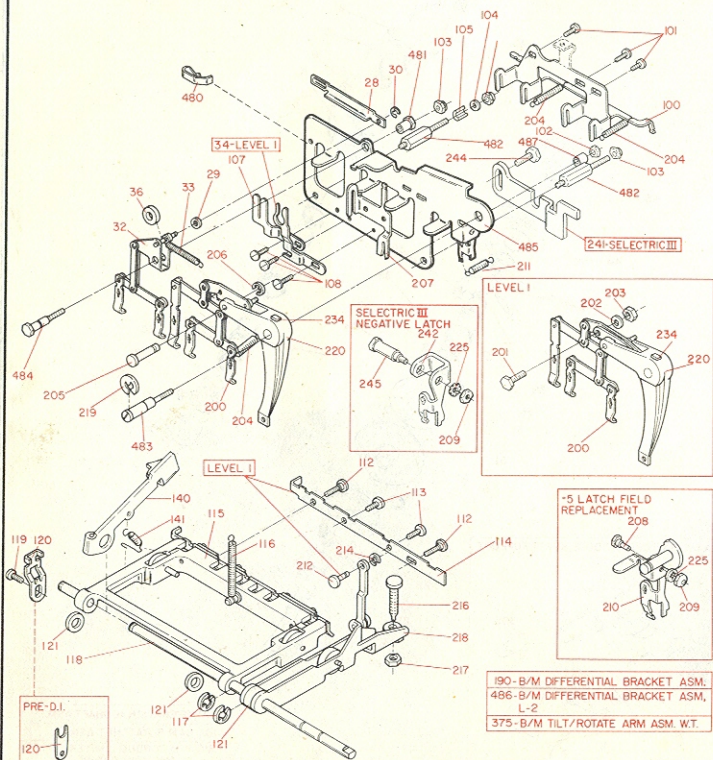

## ROTARY BACKSPACE/EXP BACKSPACE

MECH. CODE

24

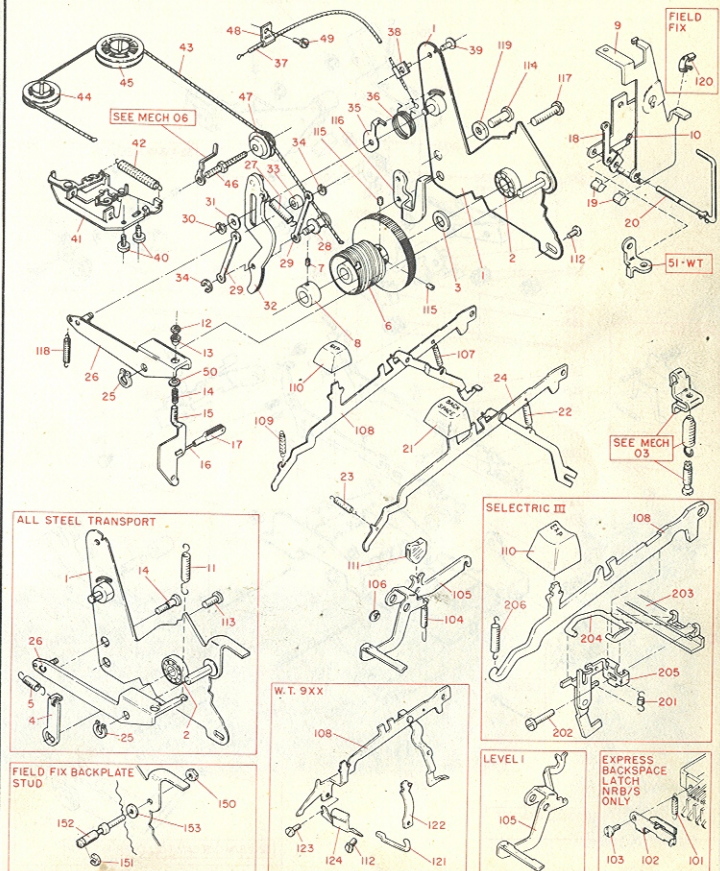

MECH. CODE

25

## OPERATIONAL CONTROL

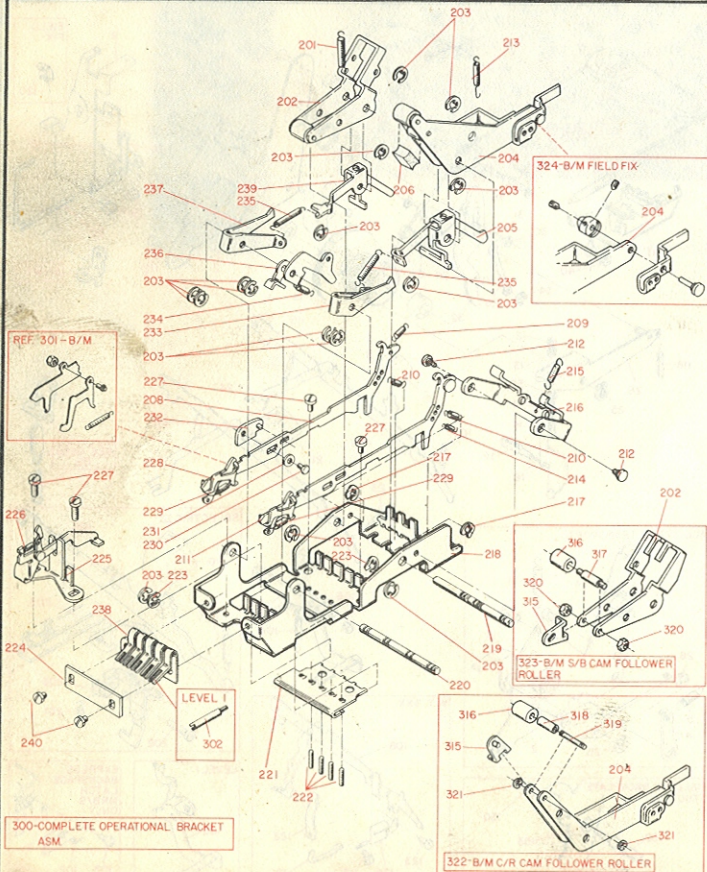

MECH. CODE

25

## OPERATIONAL SHAFT ASSEMBLY

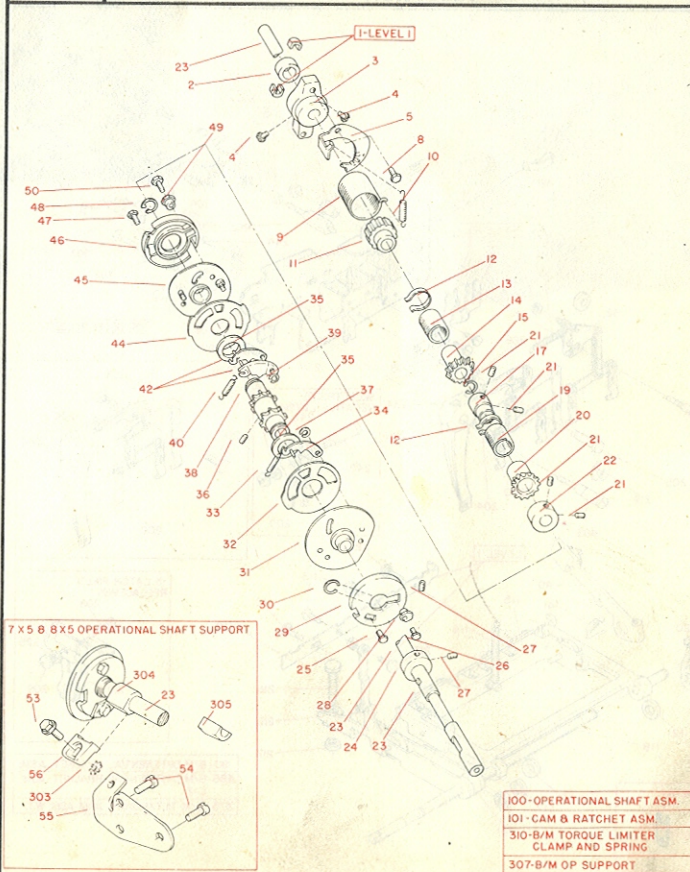

## CORRECTING

MECH. CODE

26

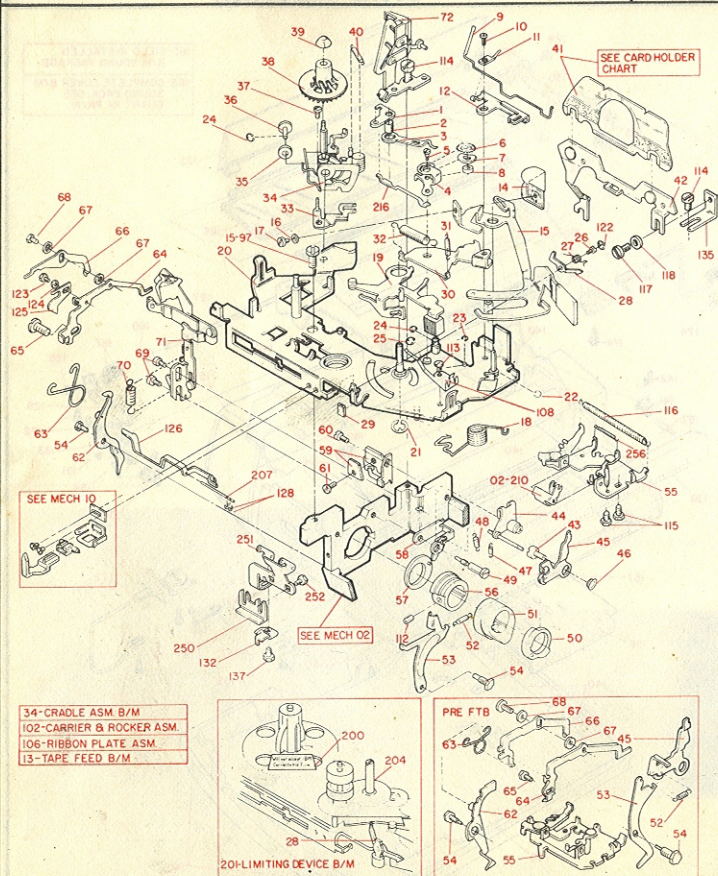

## CORRECTING

MECH. CODE

26

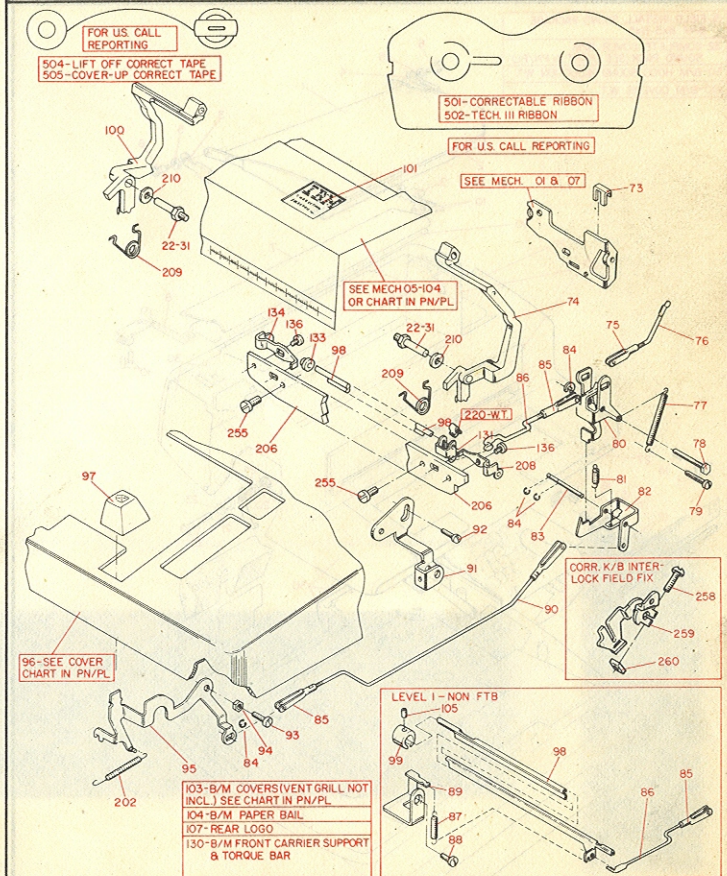

MECH. CODE

30

## SOUND REDUCTION

- 31-FIELD INSTALL SOUND PACKAGE  
B/M 8x3-8x5
- 32-COMPLETE COVER B/M  
SOUND PACK (SEE CHART IN PN/PL)
- 50-B/M HOOD SOUND REDUCTION W.T.
- 100-B/M COVERS W.T.

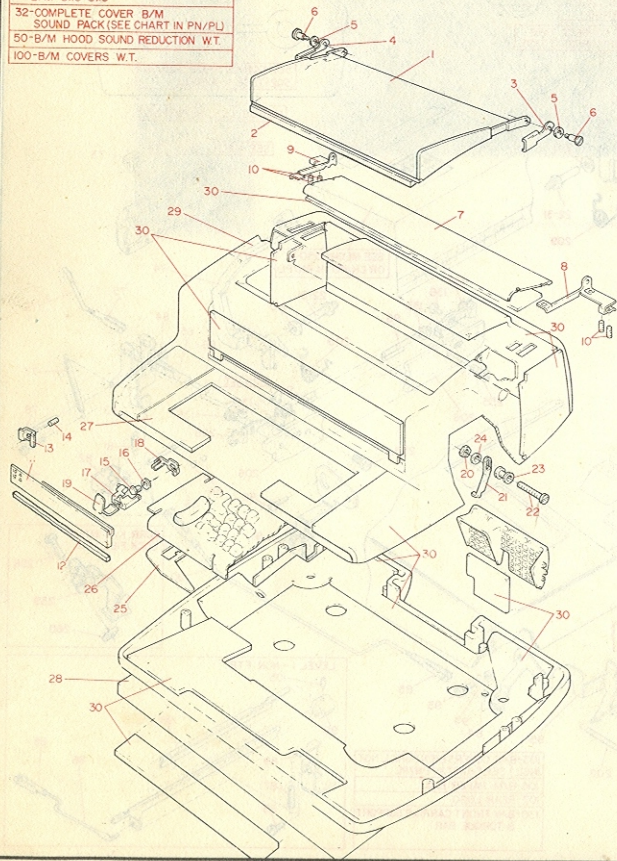

MECH. CODE

30

## SOUND REDUCTION

- 165-FIELD INSTALLED  
B/M SOUND PACKAGE
- 163-COMPLETE COVER B/M  
SOUND PACK; SEE  
CHART IN PN/PL

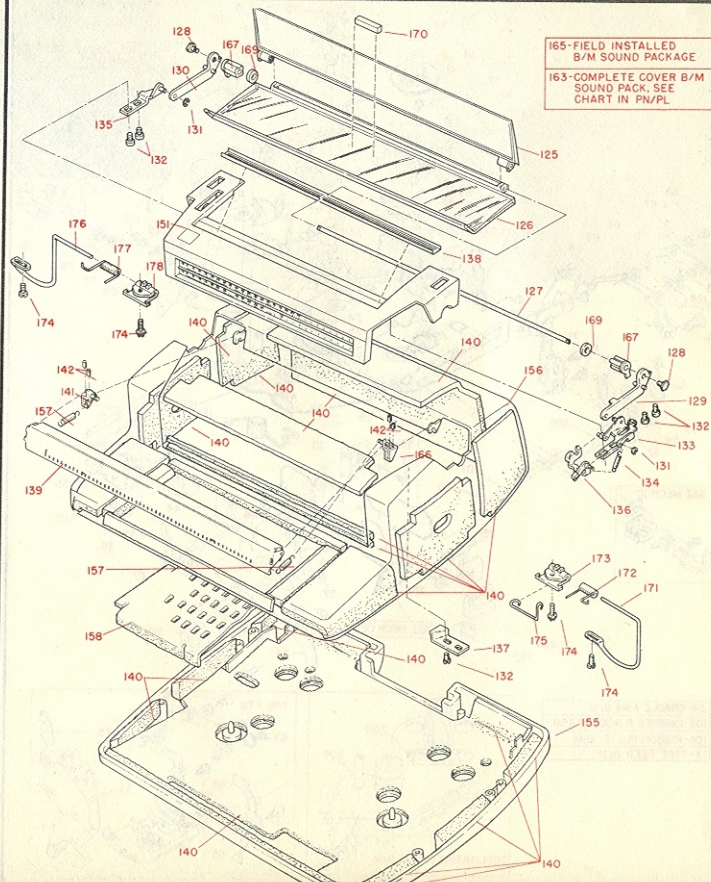

## CARD HOLDING PLATEN

MECH. CODE

39

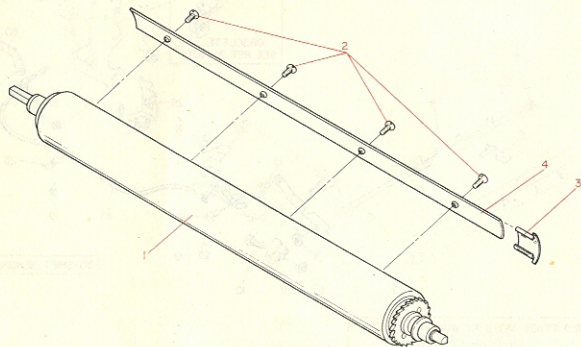

NOTE: REFER TO STD. PLATEN FOR PARTS NOT REFERENCED

## DEAD KEY

MECH. CODE

40

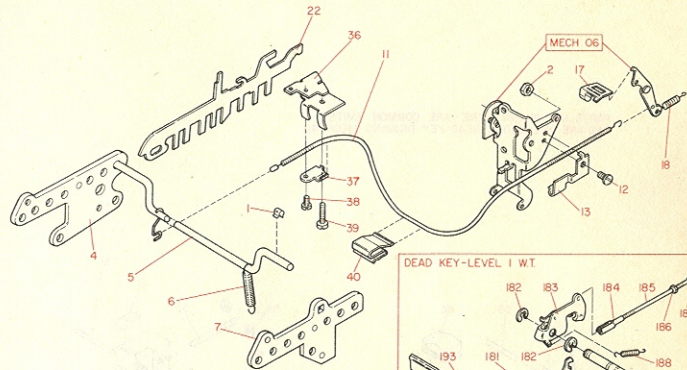

50-DEAD KEY DISCONNECT B/M FIELD INSTALLED ONLY ON MACHINES WITH U.S. SN BEGINNING WITH 5 OR 9 OR ANY SELECTRIC II

## DEAD KEY DISCONNECT

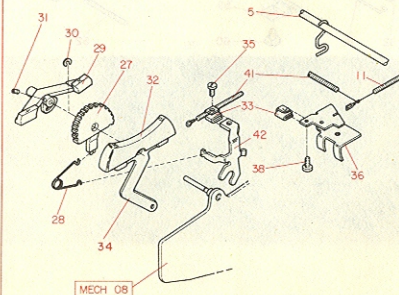

## 723 &amp; 725

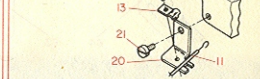

## LEVEL I

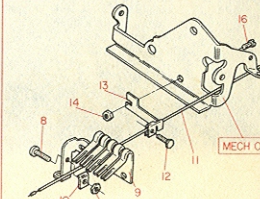

MECH. CODE

40

# W.T. DEAD KEY (THAILAND)

PARTS NOT SHOWN HERE ARE COMMON PARTS  
AND ARE INCLUDED IN DEAD KEY DRAWING MECH. 40

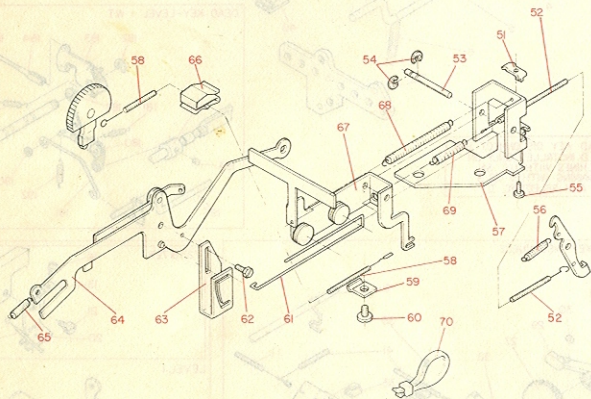

MECH. CODE

41

# SHIFT SENSING

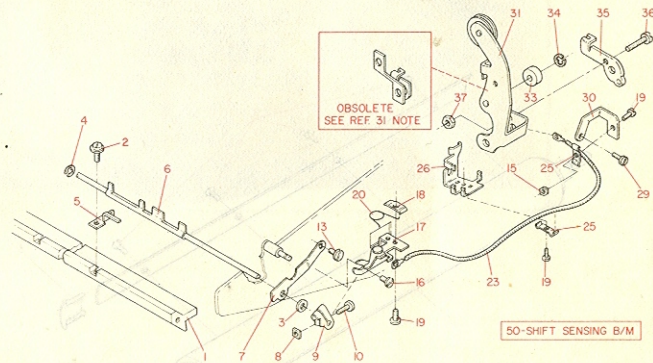

WORLD TRADE VELOCITY VANE

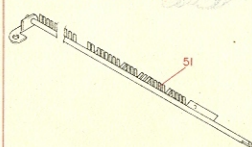

FOR WORLD TRADE VELOCITY VANE  
CONTACT THE SUPPLIER

# HANDICAPPED ATTACHMENTS

MECH. CODE  
**45**

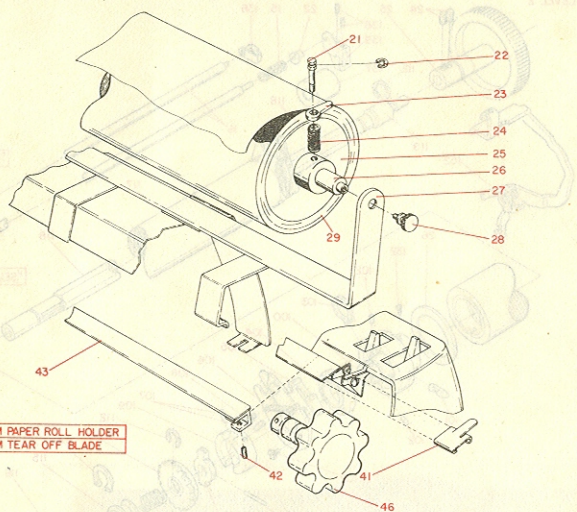

30 - B/M PAPER ROLL HOLDER  
44 - B/M TEAR OFF BLADE

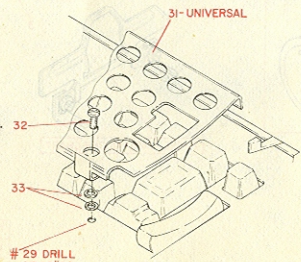

34 - B/M KEYBOARD REST

#29 DRILL  
(1360°D)

# HANDICAPPED ATTACHMENTS

MECH. CODE  
**45**

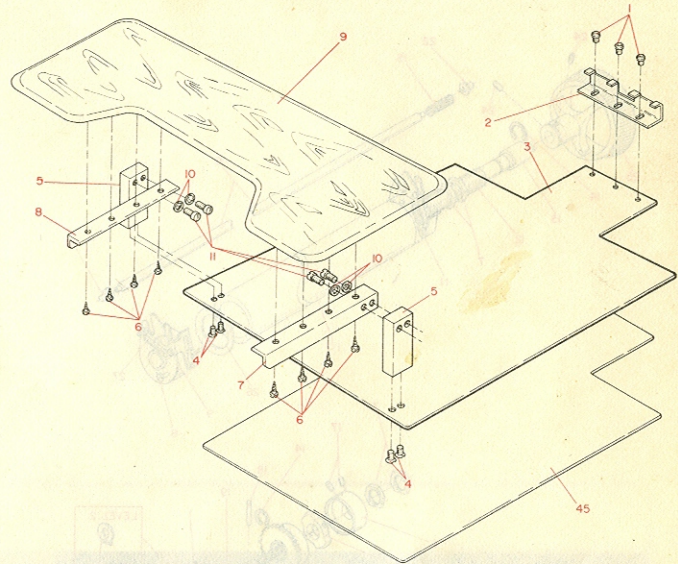

12 - B/M ARM REST



MECH. CODE

49

PIN FEED PLATEN

LEVEL 1

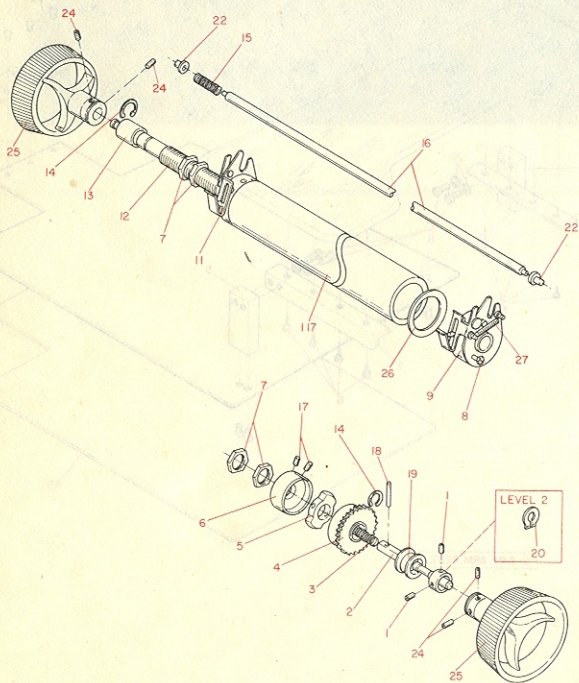

MECH. CODE

49

PIN FEED PLATEN

LEVEL 2

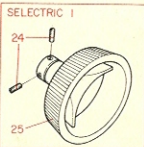
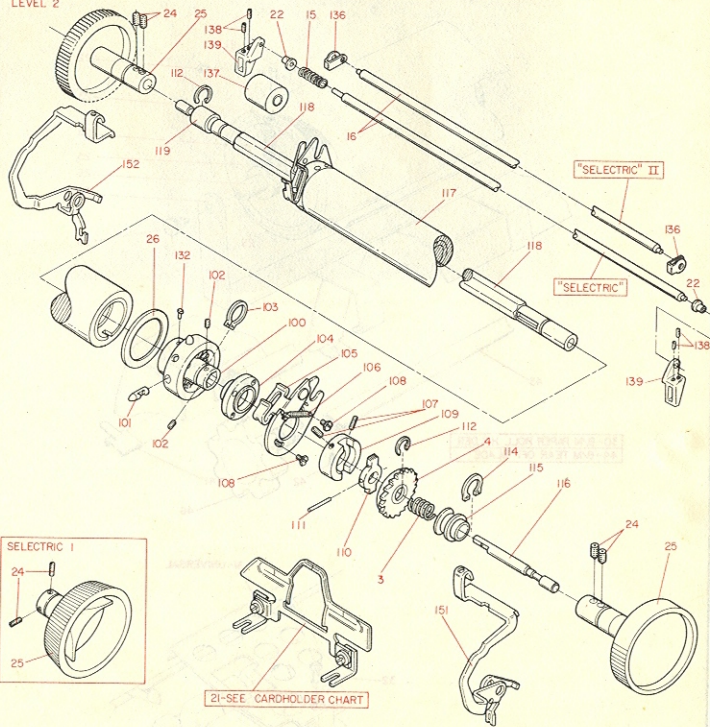

150-WT B/M PAPER BAIL
117-SPECIAL LENGTH CORES
130-PINWHEEL ASSEMBLIES
131-PINFEED PLATEN B/M'S, ORDER CORE, KNOBS, CARD HOLDER AND BRACKET

## W. T. OVERHEAD PIN FEED PLATEN

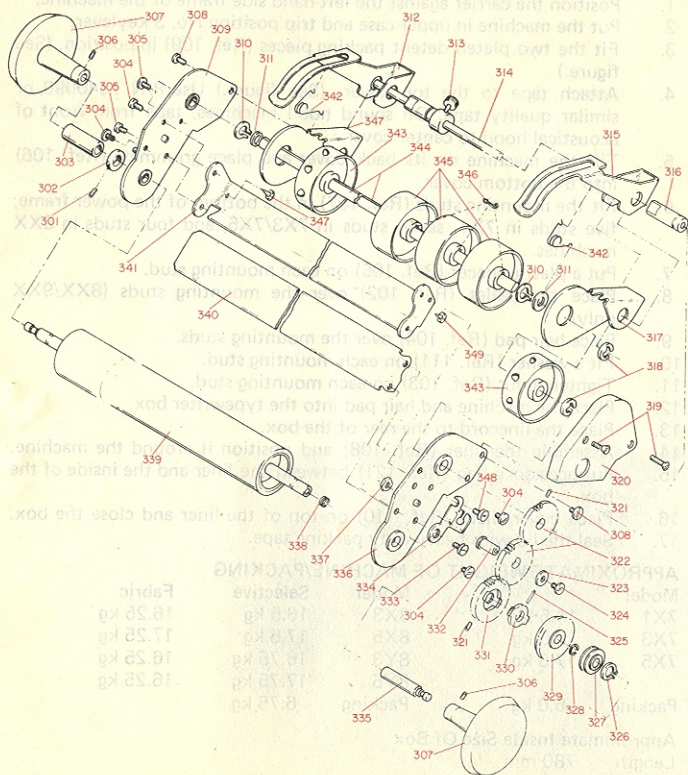
MECH. CODE  
49

## STROKE COUNTER

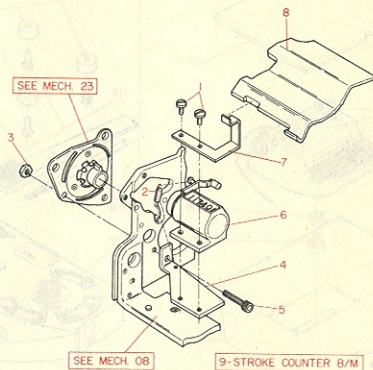
MECH. CODE  
51

MECH. CODE

65

## W.T. PACKING PARTS

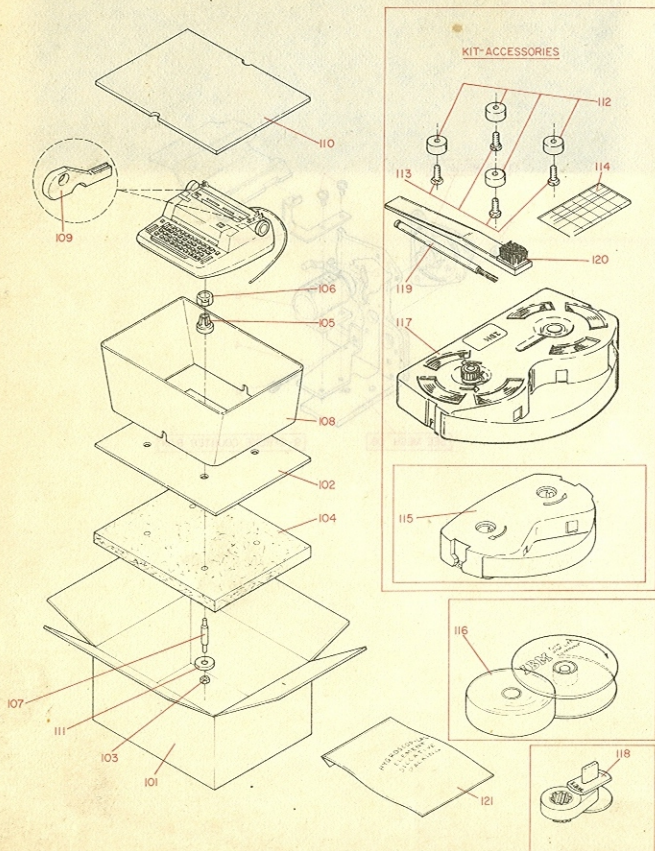

## W.T. PACKING INSTRUCTIONS

## WORLD TRADE PACKING INSTRUCTIONS

1. Position the carrier against the left-hand side frame of the machine.
2. Put the machine in upper case and trip position No. 3 keylever.
3. Fit the two platen detent packing pieces (Ref. 109) in position. (See figure.)
4. Attach tape to the top cover. (See figure.) Use P/N 7340090 or similar quality tape. On sound hood machines, tape from front of acoustical hood to center cover.
5. Tilt the machine on its back cover and place grommets (Ref. 106) into the bottom cover.
6. Fit the mounting studs (Ref. 107) in the bottom of the power frame; five studs in 7X1, seven studs in 7X3/7X5, and four studs in 8XX machines.
7. Put a plastic spacer (Ref. 105) on each mounting stud.
8. Place the pallet (Ref. 102) over the mounting studs (8XX/9XX only).
9. Place hair pad (Ref. 104) over the mounting studs.
10. Fit a washer (Ref. 111) on each mounting stud.
11. Tighten a nut (Ref. 103) on each mounting stud.
12. Place the machine and hair pad into the typewriter box.
13. Place the linecord to the rear of the box.
14. Assemble the liner (Ref. 108) and position it around the machine.
15. Put accessory bag (Ref. 121) between the liner and the inside of the box.
16. Place cover plate (Ref. 110) on top of the liner and close the box.
17. Seal the lid with heavy-duty packing tape.

## APPROXIMATE WEIGHT OF MACHINE/PACKING

Model	Model	Selective	Fabric
7X1	14.5 kg	8X3	16.25 kg
7X3	16.5 kg	8X5	17.25 kg
7X5	17.5 kg	8Y3	16.25 kg
		8Y5	16.25 kg
Packing	6.0 kg	Packing	6.75 kg

## Approximate Inside Size Of Box

Length	780 mm
Width	540 mm
Height	320 mm

## W.T. PACKING INSTRUCTIONS

### WORLD TRADE UNPACKING INSTRUCTIONS

1. Open the top of the box and remove the cover plate (Ref. 110).
2. Remove the liner (Ref. 108).
3. Lift the machine and hair pad (Ref. 104) out of the box.
4. Tilt the machine and hair pad so it rests on the back cover.
5. Remove the packing nuts (Ref. 103) and washers (Ref. 111).
6. Remove the hair pad (Ref. 104), washers (Ref. 111), and pallet (Ref. 102).
7. Remove plastic spacers (Ref. 105), mounting studs (Ref. 107), and grommets (Ref. 106).
8. Install the three nylon desk feet (Ref. 112) with screws (Ref. 113) from the accessory bag (Ref. 121).
9. Place the machine in operating position and remove tape from the top cover and carrier.
10. Remove the platen detent packing pieces (Ref. 109).
11. The machine is now ready for the preinstallation check.

### APPROXIMATE MACHINE AND CARTON WEIGHT AND SIZE

Model 7X1	32 lbs.	14.5 kg.
Model 7X3	36 lbs.	16.5 kg.
Model 7X5	37 lbs.	17.5 kg.
Model 7X7	40 lbs.	18.5 kg.
Model 7X9	44 lbs.	20.5 kg.
Model 7X3 8XX	36 lbs.	16.5 kg.
Model 7X5 8XX	37 lbs.	17.5 kg.
Model 7X7 8XX	40 lbs.	18.5 kg.
Model 7X9 8XX	44 lbs.	20.5 kg.

## BOLT DOWN INSTRUCTIONS

### BOLT DOWN INSTRUCTIONS — DROP CENTER DESKS

1. Install four mounting feet — P/N 1128485 for "Selectric" Typewriters or P/N 1205981 for "Selectric" II and III Typewriters or Correcting "Selectric" II and III Typewriters — to power frame.
2. Place a small amount of grease on the feet just around the outside of the threaded holes.
3. Set typewriter down in the correct position on the desk. Lift typewriter off the desk. The position of the holes to be made can now easily be seen.
4. Use a drill to make four holes and bolt machine to desk. See C-D Catalog, Code 204, Ref. 67 for mounting bolts.
5. CAUTION: The two front bolts must have some clearance between the bolt heads and the desk bottom. They must not pull down on the feet or the power frame may twist. The two rear feet may be tightened.

### COVER BOLT DOWN

1. Remove machine from covers.
2. Place bottom cover in correct position on desk.
3. With a cover adapter in each of the two center holes of the bottom cover, mark where to drill the hole. On the "Selectric" II Typewriter, use spacer between adapter and bottom cover.
4. Use proper length of bolt and fasten the bottom cover to the desk. To find out which bolt to use, add 1/2" (12.70 mm) to the thickness of the desk.

**CAUTION:** Bolting a machine down by other than these procedures can cause an electrical safety hazard or machine failure. An excessively long bolt could interfere with the motor windings or other inner mechanisms of the machine.

MECH. CODE

65

## U.S. PACKING PARTS

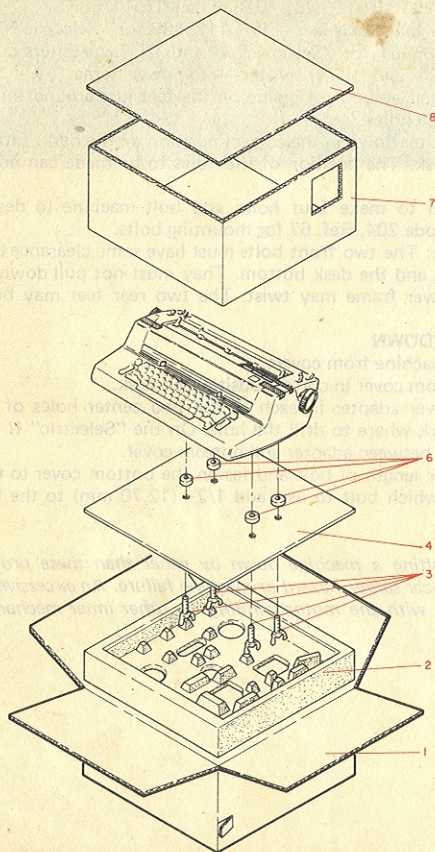

## U.S. PACKING INSTRUCTIONS

## PACKING INSTRUCTIONS

1. Position the carrier all the way to the right, latch out tab and attach Minnesota Mining Y-9035 or similar tape as shown in Mech. 765.
2. Place Minnesota Mining Y-9035 or similar tape on top cover as shown.
3. Place four rubber grommets under the bottom of the typewriter case as shown.
4. Use wing nut screws to mount the pallet to the machine.
5. Place hair pad in bottom of the box and insert machine.
6. Place liner around the machine and place cord to the back of the liner with Minnesota Mining Y-9035 or similar tape.
7. Insert chipboard tray as shown and seal the carton with tape.

**CAUTION:** Do not excessively tighten the front right-hand wing nut screw.

## UNPACKING INSTRUCTIONS

1. Open carton by pulling tear tape completely around four sides. Remove top part of the box. Remove top cardboard chipboard tray. Lift out liner by moving the sides away from the platen knobs and lift machine out of the tray.
2. Tilt machine and pallet so the machine rests on the back cover.
3. Remove the four thumb screws. These can normally be turned by hand, but, if necessary, use a pencil as an additional lever.
4. Remove pallet board and plastic spacers.
5. Remove rubber grommets from the five mounting holes in the machine bottom cover (seven on the 7X5 and 8X5).
6. Install the four nylon spacers found in the plastic accessory bag into four of the mounting holes from which the thumb screws were removed.
7. Set the machine down and remove the tape, holding the top cover and the type carrier.
8. The machine is now ready for preinstallation checkout.

## APPROXIMATE MACHINE AND CARTON WEIGHT AND SIZE

7X1 — Size 14" (355.6 mm) Deep, 15" (381.0 mm) Wide

7X5, 8X5 — Size 14" (355.6 mm) Deep, 20" (508.0 mm) Wide

Model 7X1	32 lbs.	(14.5 kg)
Models 7X3, 8X3	35 lbs.	(16.5 kg)
Models 7X5, 8X5	37 lbs.	(17.5 kg)
Carton 7X1	10 lbs.	(4.5 kg)
Cartons 7X5, 8X5, 670X	14 lbs.	(6.35 kg)

CAUSE OF FAILURE	CODE
Beat The Operation	24
Bent/Warped	01
Binding/Sticking	02
Broken/Cracked	03
Burned/Pitted/Burred	04
Card/Tape Jam	05
Dirty/Corroded	06
Flicking	25
Loose/Solder Connector	07
Low Contrast	28
Lubrication	08
Noise (Electrical)	27
Noise (Mechanical)	09
No Trouble Found	19
ON/OFF Registration	10
Open	11
Operator Error	26
Operator Preference*	22
Other	20
Out Of Adjustment	12
Out Of Alignment	13
Shorted/Grounded	14
Sound Distortion	23
Standby	21
Stripped	15
Wiring Defects	16
Weak	17
Worn	18

\*Operator Preference — Adjustment due to operator opinion which is not a malfunction of the machine.

MACHINE IDENTIFICATION CODES													
<p><b>"SELECTRIC" TYPEWRITER — PRODUCT CODE 21</b></p> <p>1st Digit — 7</p> <p>2nd Digit — 1 — Film Ribbon 2 — Fabric Ribbon</p> <p>3rd Digit — 1 — 8-1/2" writing line 3 — 11-1/2" writing line 5 — 13" writing line</p>	<p><b>"SELECTRIC" III AND CORRECTING "SELECTRIC" III TYPEWRITERS — PRODUCT CODE 27</b></p> <table border="0"> <thead> <tr> <th>MACHINE TYPE</th> <th>MODEL CODE</th> </tr> </thead> <tbody> <tr> <td>13.5" Single Pitch Fabric . . . . .</td> <td>.6701</td> </tr> <tr> <td>13.5" Single Pitch Non-Correcting . . . . .</td> <td>.6702</td> </tr> <tr> <td>15.5" Single Pitch Correcting . . . . .</td> <td>.6703</td> </tr> <tr> <td>13.5" Dual Pitch Correcting . . . . .</td> <td>.6704</td> </tr> <tr> <td>15.5" Dual Pitch Correcting . . . . .</td> <td>.6705</td> </tr> </tbody> </table>	MACHINE TYPE	MODEL CODE	13.5" Single Pitch Fabric . . . . .	.6701	13.5" Single Pitch Non-Correcting . . . . .	.6702	15.5" Single Pitch Correcting . . . . .	.6703	13.5" Dual Pitch Correcting . . . . .	.6704	15.5" Dual Pitch Correcting . . . . .	.6705
MACHINE TYPE	MODEL CODE												
13.5" Single Pitch Fabric . . . . .	.6701												
13.5" Single Pitch Non-Correcting . . . . .	.6702												
15.5" Single Pitch Correcting . . . . .	.6703												
13.5" Dual Pitch Correcting . . . . .	.6704												
15.5" Dual Pitch Correcting . . . . .	.6705												
<p><b>"SELECTRIC" II AND CORRECTING "SELECTRIC" II TYPEWRITERS — PRODUCT CODE 26</b></p> <p>1st Digit — 8</p> <p>2nd Digit — 3 — Single Pitch Selective Ribbon 4 — Single Pitch Fabric Ribbon 5 — Single Pitch Correcting "Selectric" Typewriter 7 — Dual Pitch Selective Ribbon 8 — Dual Pitch Fabric Ribbon 9 — Dual Pitch Correcting "Selectric" Typewriter</p> <p>3rd Digit — 3 — 11" writing line 5 — 13" writing line</p>	<p><b>96-CHARACTER "SELECTRIC" TYPEWRITER</b></p> <p>1st Digit — 9</p> <p>2nd Digit — 6 — Single Pitch Selective Ribbon 4 — Single Pitch Fabric Ribbon 5 — Single Pitch Correcting "Selectric" Typewriter 1 — Dual Pitch Selective Ribbon 2 — Dual Pitch Fabric Ribbon 9 — Dual Pitch Correcting "Selectric" Typewriter</p> <p>3rd Digit — 3 — 11" writing line 5 — 13" writing line</p>												